

UNITED STATES
CONSUMER PRODUCT SAFETY COMMISSION



LABORATORY TEST MANUAL

FOR

16 CFR Parts 1615 and 1616:

Standards for the Flammability of Children's Sleepwear

July 2010

This test manual was prepared by CPSC staff and has not been reviewed or approved by, and may not necessarily represent the views of, the Commission.

TABLE OF CONTENTS

LIST OF TABLES3

LIST OF FIGURES3

1. SCOPE5

2. SUMMARY OF 16 CFR PARTS 1615 and 16165

3. PERFORMANCE REQUIREMENTS5

4. GENERAL EQUIPMENT LIST6

5. CALIBRATION OF TEST INSTRUMENTS6

6. SAFETY.....7

7. REQUIREMENTS OF THE STANDARDS AND TEST OVERVIEW.....7

8. SAMPLING PLANS9

 8.1 Fabric Production Unit Sampling9

 8.1.1 Normal Sampling Plan..... 10

 8.1.2 Tightened Sampling Plan..... 11

 8.1.3 Reduced Sampling Plan..... 13

 8.1.4 Disposition Testing of Rejected Units 14

 8.2 Garment Production Unit Sampling.....18

 8.2.1 Prototype Testing 18

 8.2.2 Production Testing 22

 8.2.3 Disposition of Rejected Units 24

9. SAMPLE PREPARATION.....25

 9.1 Prepare Test Specimens25

 9.2 Mounting the Specimens.....28

10. SAMPLE CONDITIONING30

11. TEST PROCEDURE33

 11.1 Flammability Test33

 11.2 Char Length Determination37

12. LAUNDERING40

13. TEST REPORT AND CERTIFICATION43

14. RECORDKEEPING44

 14.1 General.....44

 14.2 Fabrics.....44

 14.3 Garments44

 14.3.1 Prototype Testing 44

 14.3.2 Production Testing 45

 14.4 Retention Requirements45

APPENDICES46

 Appendix A: Description of Test Equipment47

 Appendix B: Requirements for Tight-fitting Garments49

 Appendix C: Definition of Children's Sleepwear and Related Terms54

 Appendix D: Exemptions/Exceptions56

 Appendix E: Trim57

 Appendix F: Glossary of Terms.....59

LIST OF TABLES

Table 1. Conditioning Requirements 30
 Table 2. Conditioned Fabric Weight (Finished State) 38
 Table 3. Washing and Drying Conditions 40
 Table 4. Technical Requirements for Laundering 40
 Table 5. Maximum Measurements for Tight-fitting Children's Sleepwear by Size 50
 Table 6. Distance from Shoulder to Upper Arm by Size [cm (in)] 52

LIST OF FIGURES

Figure 1. Test overview. 8
 Figure 2. Fabric Production Unit Flowchart (Normal Sampling Plan) 10
 Figure 3. Example of sampling from one fabric piece 11
 Figure 4. Example of sampling from two fabric pieces 11
 Figure 5. Example of sampling from three fabric pieces 11
 Figure 6. Fabric Production Unit Flowchart (Tightened Sampling Plan) 12
 Figure 7. Fabric Production Unit Flowchart (Reduced Sampling Plan) 13
 Figure 8. Fabric Production Unit Flowchart (Disposition Testing, Unit) 16
 Figure 9. Fabric Production Unit Flowchart (Disposition Testing, Piece by Piece) 17
 Figure 10. Garment Production Unit Flowchart (Prototype, Seams) 19
 Figure 11. Garment Production Unit Flowchart (Prototype, Trim) 21
 Figure 12. Garment Production Unit Flowchart (Production, Normal Sampling Plan) 23
 Figure 13. Garment Production Unit Flowchart (Production, Normal Sampling Plan, Modified) 23
 Figure 14. Garment Production Unit Flowchart (Production, Reduced Sampling Plan) 24
 Figure 15. Use template to prepare fabric specimen 25
 Figure 16. Prepare seam specimen 26
 Figure 17. Attach trim to fabric specimen 27
 Figure 18. Align specimen with edge of specimen holder 28
 Figure 19. Position specimen on back plate 28
 Figure 20. Position seam specimen 28
 Figure 21. Tape may be used to further secure specimen 29
 Figure 22. Clips on holders 29
 Figure 23. Place specimens in oven 30
 Figure 24. Set timer 31
 Figure 25. Remove specimens from oven 31
 Figure 26. Place specimen in desiccator 32
 Figure 27. Light igniter 33
 Figure 28. Check flame length 33
 Figure 29. Use fuel valve to adjust flame length 34
 Figure 30. Remove specimen from desiccator 34
 Figure 31. Place specimen on rack 35
 Figure 32. Position mounted specimen 35
 Figure 33. Set stopwatch 36
 Figure 34. Slide ignition mechanism forward 36
 Figure 35. Use extinguishing plate if afterglow is present 37
 Figure 36. Fold specimen 37

Figure 37. Hook weight onto specimen	38
Figure 38. Gently lift specimen.	38
Figure 39. Measure char length.....	39
Figure 40. Check water temperature.....	41
Figure 41. Weigh detergent.....	41
Figure 42. Weights for char length determination	48
Figure 43. Specimen holder	48
Figure 44. Measure chest.....	51
Figure 45. Measure waist.....	51
Figure 46. Measure upper arm.....	52
Figure 47. Measure seat.....	52
Figure 48. Measure thigh.....	53
Figure 49. Measure ankle.....	53
Figure 50. Test ruffles as trim.....	57
Figure 51. Functional tank strap	58
Figure 52. Attachment point less than 6 mm from edge of elasticized trim.....	58
Figure 53. Test trim pieces greater than 5.18 cm in longest direction.....	58

1. SCOPE

This U.S. Consumer Product Safety Commission (CPSC) staff laboratory test manual is a reference guide designed to assist with the testing procedures specified in the *Standards for the Flammability of Children's Sleepwear* codified at 16 CFR Parts 1615 and 1616 (the Standards).

This test manual is not the complete mandatory standard, but is a tool that may be used in conjunction with the requirements specified in the Standards. The test manual is provided for guidance purposes only and is not intended to be fully inclusive of the test procedures, nor is it intended to replace or supersede any sections of the Standards. In the case of any discrepancies between this manual and the Standards, the Standards will supersede this test manual.

The test manual also identifies the test equipment used to perform the testing in accordance with the Standards. The descriptions and pictures in this manual are not meant to serve as specifications or recommendations of any brand, make, or model of instrumentation that must be used to comply with the Standards, but rather as examples for clarification purposes.

2. SUMMARY OF 16 CFR PARTS 1615 and 1616

The Standards for the flammability of children's sleepwear were issued to reduce the unreasonable risk of burn injuries and deaths from fire associated with children's sleepwear. Most burn incidents do not occur while children are sleeping but while they are awake, unsupervised, and wearing sleepwear. The primary hazard is ignition of the sleepwear by contact with hot surfaces and/or small open-flame ignition sources, such as stove elements, matches, and lighters. The Standards require that children's sleepwear and fabric intended for such sleepwear stop burning when the flame source is removed.

In 1996, the CPSC published amendments to the Standards that except sleepwear garments from the flammability requirements if they are:

- Size 9 months and smaller, or
- Tight-fitting as defined in §1615.1(o) and §1616.2(m).

See *Appendix B. Requirements for Tight-fitting Garments* for more information on this exception.

3. PERFORMANCE REQUIREMENTS

In order to meet the requirements of the Standards, children's sleepwear must meet the following criteria stated below and in §1615.3(b) and §1616.3(b):

- The average char length of the sample does not exceed 17.8 cm (7.0 in) and
- No individual specimen has a char length of 25.4 cm (10.0 in).

4. GENERAL EQUIPMENT LIST

Perform the flammability test in a fume hood that has the ability to fully evacuate the combustion products caused by testing. The fume hood must have the capability of being turned off during a test. Beyond those basic facility requirements, the list below is a suggested equipment list for performing the test. Required equipment is indicated by an asterisk, “*.” Other equipment is recommended. Refer to *Appendix A: Description of Test Equipment* for information on test equipment. Specific equipment lists are provided at the beginning of each test section.

1. Automatic washing machine and dryer*
2. Balance/scale*
3. Ballast for laundering*
4. Circulating ovens*
5. Desiccant*
6. Desiccator*
7. Die/template for preparing fabric weight specimens
8. Extinguishing plate*
9. Gloves, insulated
10. High vacuum grease to seal desiccators
11. Hooks and weights*
12. Laundering detergent*
13. Liner (non-flammable) for test chamber floor
14. Methane, at least 97% pure*
15. Regulator*
16. Scale (ruler) marked in 1 mm or 0.1 in increments*
17. Sewing machine
18. Specimen holders and clips*
19. Specimen preparation materials such as scissors, marking pens, and tape
20. Specimen template, 8.9 by 25.4 cm (3.5 by 10.0 in)
21. Stop watch*
22. Test chamber (which includes the burner ignition mechanism)*
23. Thermometer or thermocouple
24. Thread

5. CALIBRATION OF TEST INSTRUMENTS

Maintain all equipment used in the performance of these tests in conformance with the specifications required by 16 CFR Parts 1615 and 1616 and the suggested maintenance and calibration schedules.

6. SAFETY

Perform all burn tests under a properly functioning fume hood. Testing personnel should have personal protective equipment available that is appropriate for the test environment and should be cleared and trained to use it. Insulated gloves should be available for removal of specimens from the circulating oven. A method of fire suppression should be ready to use when testing specimens. Monitor all ignited specimens closely for situations that would present a danger to test personnel and/or the test facility. Monitor suppressed specimens for re-ignition and package specimen remains properly. Follow appropriate safety measures for working with combustible gases.

7. REQUIREMENTS OF THE STANDARDS AND TEST OVERVIEW

The children's sleepwear flammability Standards, 16 CFR Parts 1615 and 1616, state the flammability performance required for sleepwear sized larger than 9 months to 14. Additionally, the Standards include exact dimensions for tight-fitting sleepwear, an exception to the Standards. (For tight-fitting garment requirements, see *Appendix B. Requirements for Tight-fitting Garments.*)

The Standards require that children's sleepwear garments that are not tight-fitting follow specific sampling plans and be tested for flammability performance at several stages of production. The Standards have performance requirements for fabric, prototype (seams and trim), and production units. The following list summarizes sample preparation for testing:

- Fabric Production Unit (FPU)
For fabrics that are promoted for use in children's sleepwear, prepare either four or six samples of five specimens each, depending on the type of sampling required (see section 8. *Sampling*). Half of the samples prepared will be tested in the finished state (either in original state or after one laundering) and the other half will be laundered (wash and dry) for 50 cycles. Prepare a second full set of specimens for recordkeeping requirements (see section 14. *Recordkeeping*).
- Garment Production Unit (GPU)
Once a garment design is proposed, test prototypes of the seams and decorative trims to be used in the garment. For GPU prototype recordkeeping requirements, maintain a second set of prototype specimens and a complete production garment (see section 14. *Recordkeeping*). It is suggested that more than one production garment be retained.
 - Prototype
 - Seams: Prepare three samples of five specimens each of each seam type to be used in the garment.
 - Trim: Prepare three samples of five specimens each for each type of decorative trim to be used in the garment.
 - Production
 - Garments: Prepare three samples of five specimens each of the longest seam type. If the fabric used in the garment has not been tested after laundering, the garment will need to undergo the laundering protocol and be retested.

Figure 1 outlines the basic steps for performing the test as described in §1615.4 and §1616.5.

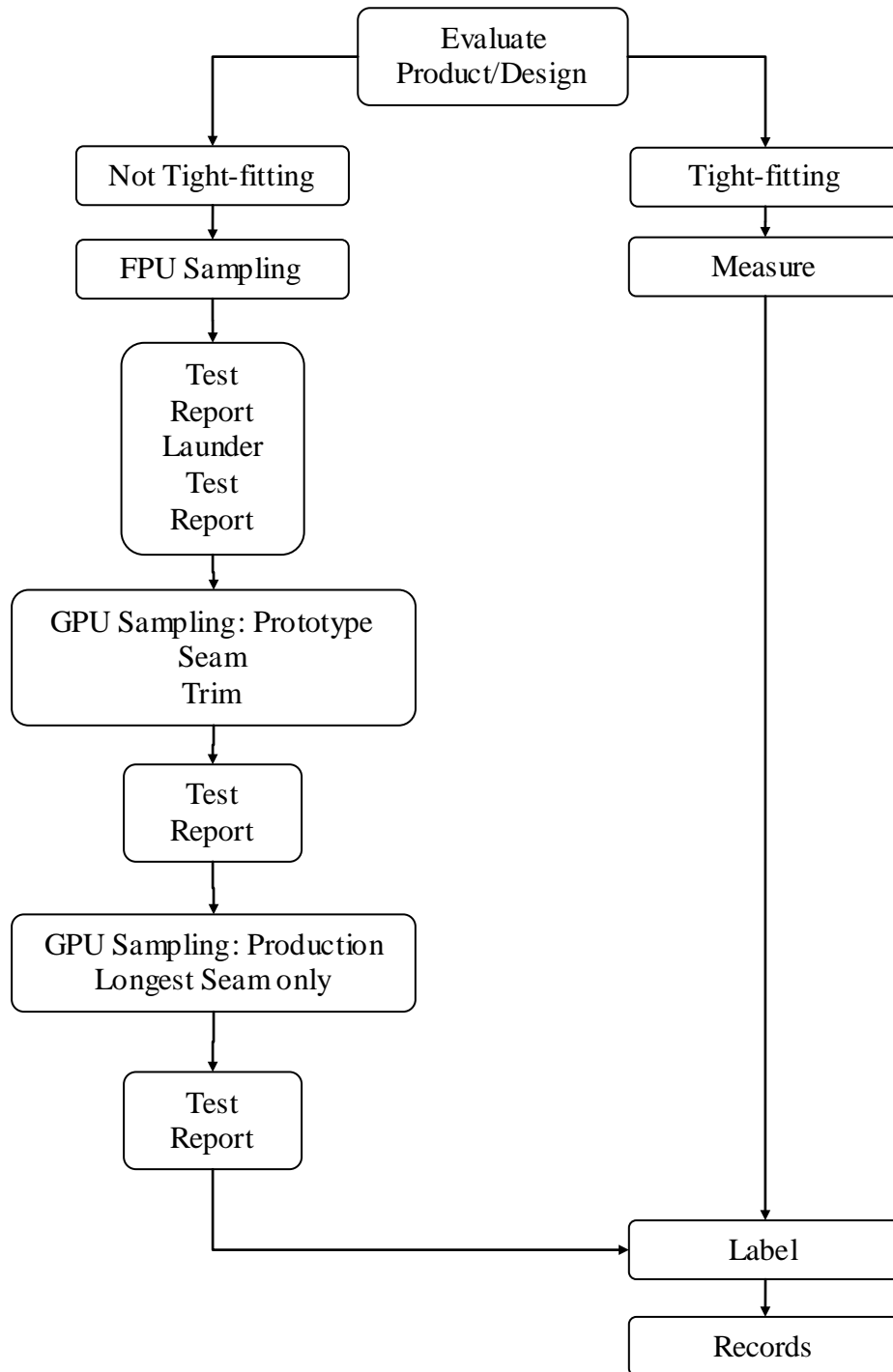

Figure 1. Test overview.

8. SAMPLING PLANS

Sampling plans are used to comply with the testing requirements of 16 CFR Parts 1615 and 1616. The plans described below are specified in the Standards; however, the CPSC staff may consider and approve other sampling plans that are shown to provide an equivalent level of safety to the consumer.

The procedures described in the sampling plans are carried out on finished items:

- Either as produced or after one washing and drying cycle (FPU and GPU),
and
- After 50 washing and drying cycles (FPU). (Refer to section 12. *Laundering* for details of the laundering procedure.)



It is suggested that good fabric sampling practices be used when preparing specimens for testing. For example, specimens should not share warp and filling yarns when possible. Additionally, specimens should not be located too close to the fabric selvage and should originate from different areas of the fabric sampled.

8.1 Fabric Production Unit Sampling

A fabric production unit (FPU) is defined as a quantity of fabric up to 4,600 linear meters (5,000 linear yards) for Normal and Tightened Sampling and 9,200 linear meters (10,000 linear yards) for Reduced Sampling. An FPU retains a specific identity throughout the unit except for color or print pattern as specified in §1615.4 (b) and §1616.4(a).



An FPU can be made up of fabrics of different colors or different print patterns in the same colorways (but **not both** different colors and different prints). In order to include different colors or different print patterns (or the same pattern in different colorways), three samples from each color or print must be tested and shown to be equivalent in performance.

Test all initial FPUs in the finished state (either as produced or after one laundering cycle) and after 50 laundering cycles. For fabrics that are not treated with a flame retardant **at any stage** during production, test subsequent FPUs in the finished state only.

8.1.1 Normal Sampling Plan

Two samples are taken from each FPU. A sample (five specimens) is taken from each end of the fabric piece. If the FPU is made up of more than one fabric piece, take one sample from the beginning of the first fabric piece in the unit and the other sample from the end of the last fabric piece in the unit.

See section 9. *Sample Preparation* for more information on specimen preparation.

The flowchart in Figure 2 outlines the test sequence and criteria. See §1615.4(c)(1) and §1616.4(b)(1) for more information on the test sequence and criteria.

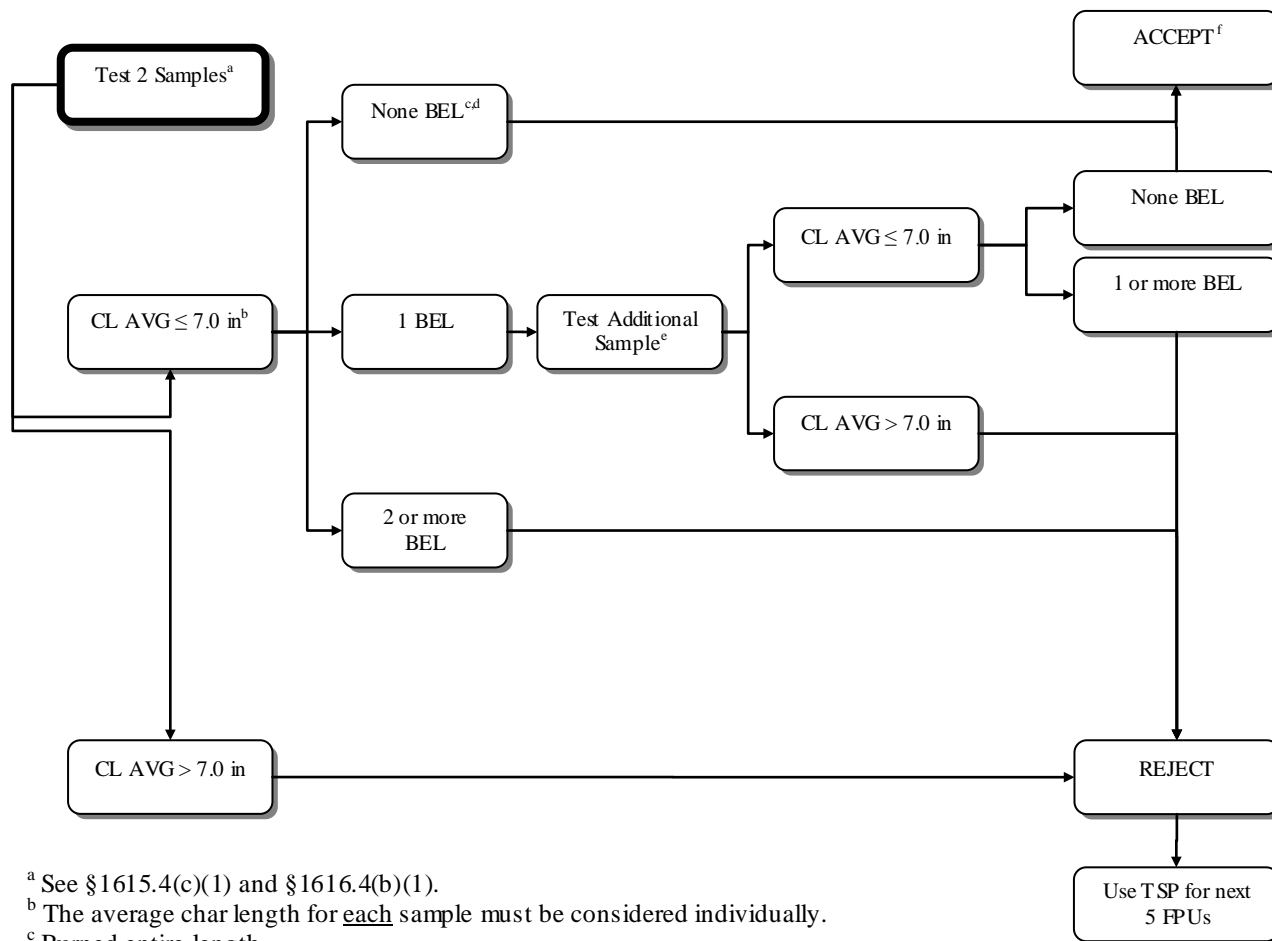

^a See §1615.4(c)(1) and §1616.4(b)(1).

^b The average char length for each sample must be considered individually.

^c Burned entire length.

^d Individual specimen(s) out of all samples.

^e Sample (5 specimens) are taken from same end and direction from which failure came.

^f Once 15 consecutive FPUs have been accepted, the Reduced Sampling Plan may be used.

Figure 2. Fabric Production Unit Flowchart (Normal Sampling Plan)

8.1.2 Tightened Sampling Plan

Use the Tightened Sampling Plan¹ if an FPU is rejected under the Normal Sampling Plan. Prepare three samples for the next test sequence. Depending upon how many fabric pieces make up the FPU, prepare the FPU according to the following instructions:

- One fabric piece – Divide the fabric into at least two pieces of at least 92 linear meters (100 linear yards), but no more than 2,300 linear meters (2,500 linear yards). After division, follow either the instruction for sampling an FPU made up of two fabric pieces or for sampling an FPU made up of three or more fabric pieces.

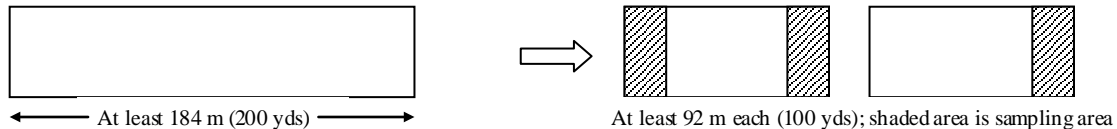

Figure 3. Example of sampling from one fabric piece

- Two fabric pieces - Select three samples. Take one sample from the beginning of the first fabric piece, one sample from the end of the second fabric piece, and the middle sample from the unit interior at the end of either piece.

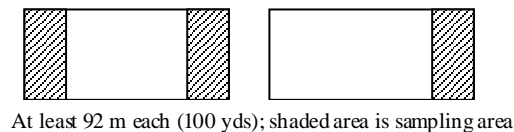

Figure 4. Example of sampling from two fabric pieces

- Three or more fabric pieces – Take three samples, one from the beginning of the first fabric piece, one from a middle fabric piece, and one from the end of the last fabric piece in the FPU.

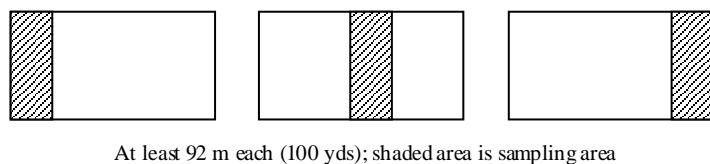

Figure 5. Example of sampling from three fabric pieces

See section 9. *Sample Preparation* for more information on specimen preparation.

The flowchart in Figure 6 outlines the test sequence and criteria. See §1615.4(c)(3) and §1616.4(b)(3) for more information on the test sequence and criteria.



Resume Normal Sampling when **five consecutive** FPUs have been accepted under the Tightened Sampling Plan.

Discontinue production of the fabric if the Tightened Sampling Plan remains in effect for **15 consecutive** FPUs.

¹ The Tightened Sampling Plan covers the same linear yardage as the Normal Sampling Plan except that an additional sample is taken from the middle of the FPU.

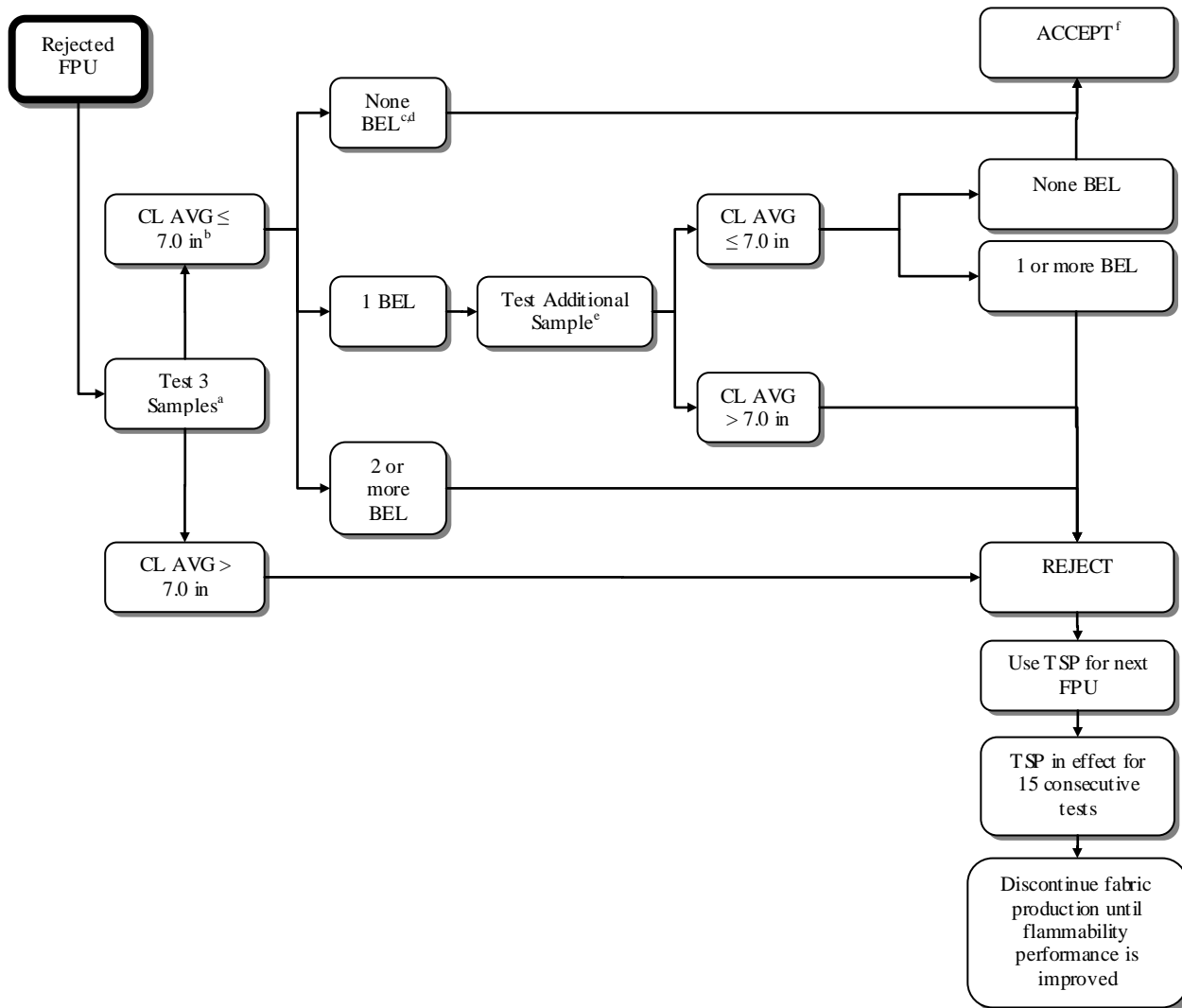

^a See §1615.4(c)(3) and §1616.4(b)(3).

^b The average char length for each sample must be considered individually.

^c Burned entire length.

^d Individual specimen(s) out of all samples.

^e Sample (5 specimens) is taken from same end, piece, and direction from which the failure came.

^f Normal Sampling may be resumed once 5 consecutive units have been accepted under Tightened Sampling.

Figure 6. Fabric Production Unit Flowchart (Tightened Sampling Plan)

8.1.3 Reduced Sampling Plan

Use the Reduced Sampling Plan² after **15 consecutive** FPU's of the same fabric have been accepted under the Normal Sampling Plan. Decrease the frequency of sampling by increasing the FPU to 9,200 linear meters (10,000 linear yards) under the Reduced Sampling Plan. Select and test two samples from the FPU following the same procedure as for the Normal Sampling Plan in section 8.1.1 of this manual. In the case of a rejection, reinstitute the Normal Sampling Plan.

The flowchart in Figure 7 outlines the test sequence and criteria. See §1615.4(c)(2) and §1616.4(b)(2) for more information on the test sequence and criteria.

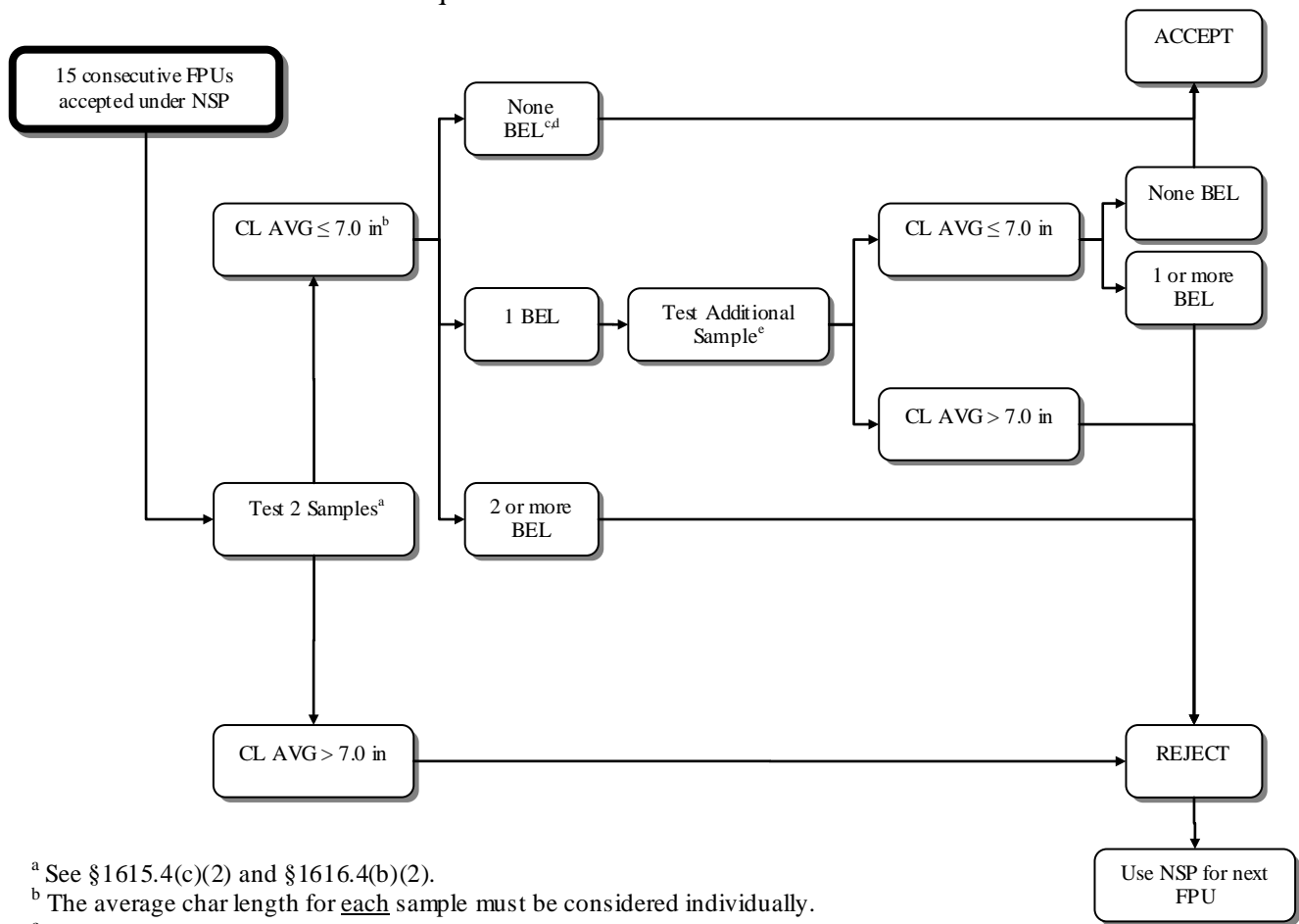

^a See §1615.4(c)(2) and §1616.4(b)(2).

^b The average char length for each sample must be considered individually.

^c Burned entire length.

^d Individual specimen(s) out of all samples.

^e Sample (5 specimens) is taken from same end, piece, and direction from which the failure came.

Figure 7. Fabric Production Unit Flowchart (Reduced Sampling Plan)

² Using the Reduced Sampling Plan is optional, not required.

8.1.4 Disposition Testing of Rejected Units

A rejected unit may be accepted when retested following the Disposition Testing procedures specified in the Standards. The retesting procedures require testing the fabric pieces adjacent to each failed piece in the FPU.

Remove all failing fabric pieces from a rejected production unit before retesting. The remaining FPU should consist of at least 15 pieces of fabric for Disposition Testing. For FPUs that do not contain at least 15 pieces of fabric, divide the FPU into pieces based on the length of the FPU³.

- 1,380 linear meters (1,500 linear yards) or more: Divide the unit into at least 15 equal pieces of at least 92 linear meters (100 linear yards) each.
- Less than 1,380 linear meters (1,500 linear yards): Divide the unit into equal pieces of approximately 92 linear meters (100 linear yards) each.

Number the fabric pieces in the FPU based on production or processing order. Clearly identify the location of the failed fabric piece(s) within the FPU.

Conduct Disposition Testing using the appropriate retest method. If there are more than five fabric pieces remaining after dividing the FPU, test using either the Unit Retest Method⁴ or the Piece by Piece Retest Method⁵. If there are five pieces or less remaining, test using only the Piece by Piece Retest Method. [§1615.4(c)(4)(iii); §1616.4(b)(4)(iii)]



In order to conduct the Piece by Piece Retest Method, at least three pieces must remain after dividing the FPU. [§1615.4(c)(4)(vi); §1616.4(b)(4)(vi)] When less than three fabric pieces remain after dividing the unit, no retesting (disposition testing) can be performed and the unit is rejected.

FPUs (including all fabric pieces in the unit) rejected after disposition testing may not be retested, used, or promoted for use in children's sleepwear unless the flammability performance is improved. When the flammability characteristics are improved through further processing, the fabric piece(s) may be retested and accepted under the Tightened Sampling Plan. [§1615.4(c)(4)(vii); §1616.4(b)(4)(vii)]

³ After removing all failing pieces from the FPU.

⁴ The test plan outlined in §1615.4(c)(4)(iv)-(v) and §1616.4(b)(4)(iv)-(v) is referred to in this manual as the "Unit Retest Method".

⁵ The test plan outlined in §1615.4(c)(4)(vi) and §1616.4(b)(4)(vi) is referred to in this manual as the "Piece by Piece Retest Method".

8.1.4.1 Unit Retest Method

Test two samples from each fabric piece remaining in the FPU. Take a sample from each end of the fabric pieces adjacent to the failed fabric piece(s).

See section 9. *Sample Preparation* for more information on specimen preparation.

The flowchart in Figure 8 outlines the test sequence and criteria. See §1615.4(c)(4)(iv-v) and §1616.4(b)(4)(iv-vi) for more information on the test sequence and criteria.

Continue testing adjoining fabric pieces until an acceptable piece is found. Then continue testing adjoining pieces until:

- Three successive fabric pieces are acceptable within the first five additional pieces tested (excluding the first acceptable fabric piece). The three acceptable pieces and the remainder of the FPU will be accepted.
- Five successive fabric pieces do not yield three successive acceptable results (excluding the first acceptable fabric piece). Stop testing and reject the entire FPU.

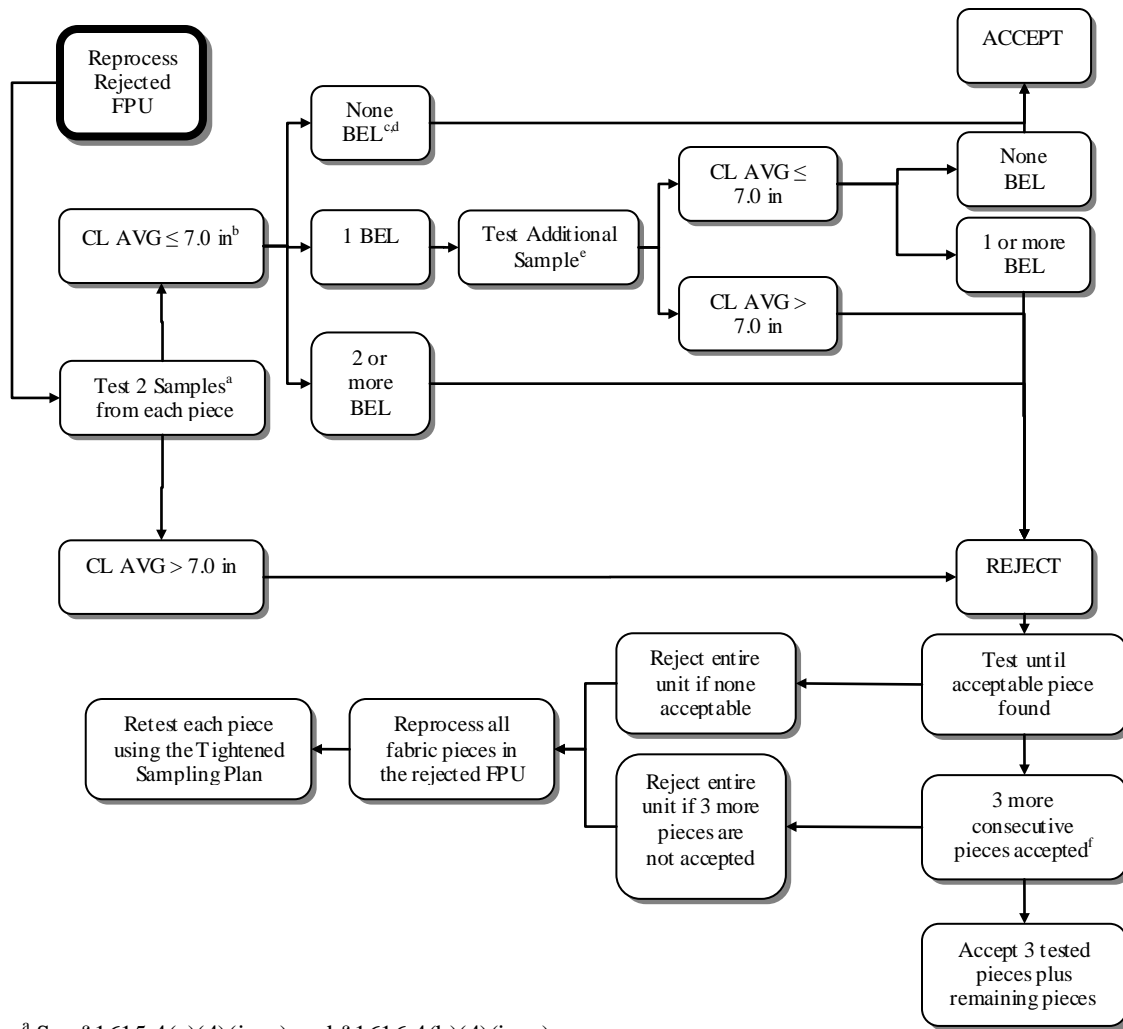

^a See § 1615.4(c)(4)(iv-v) and § 1616.4(b)(4)(iv-v).

^b The average char length for each sample must be considered individually.

^c Burned entire length.

^d Individual specimen(s) out of all samples.

^e Sample (5 specimens) are taken from same end, piece, and direction from which the failure came.

^f These 3 tests must occur in 5 or fewer total consecutive tests, not including the first acceptable piece.

Figure 8. Fabric Production Unit Flowchart (Disposition Testing, Unit)

8.1.4.2 Piece by Piece Retest Method

Test four samples from each fabric piece remaining in the FPU. Take two samples from each end of the fabric pieces.

See section 9. *Sample Preparation* for more information on specimen preparation.

The flowchart in Figure 9 outlines the test sequence and criteria. See §1615.4(c)(4)(vi) and §1616.4(b)(4)(vi) for more information on the test sequence and criteria.

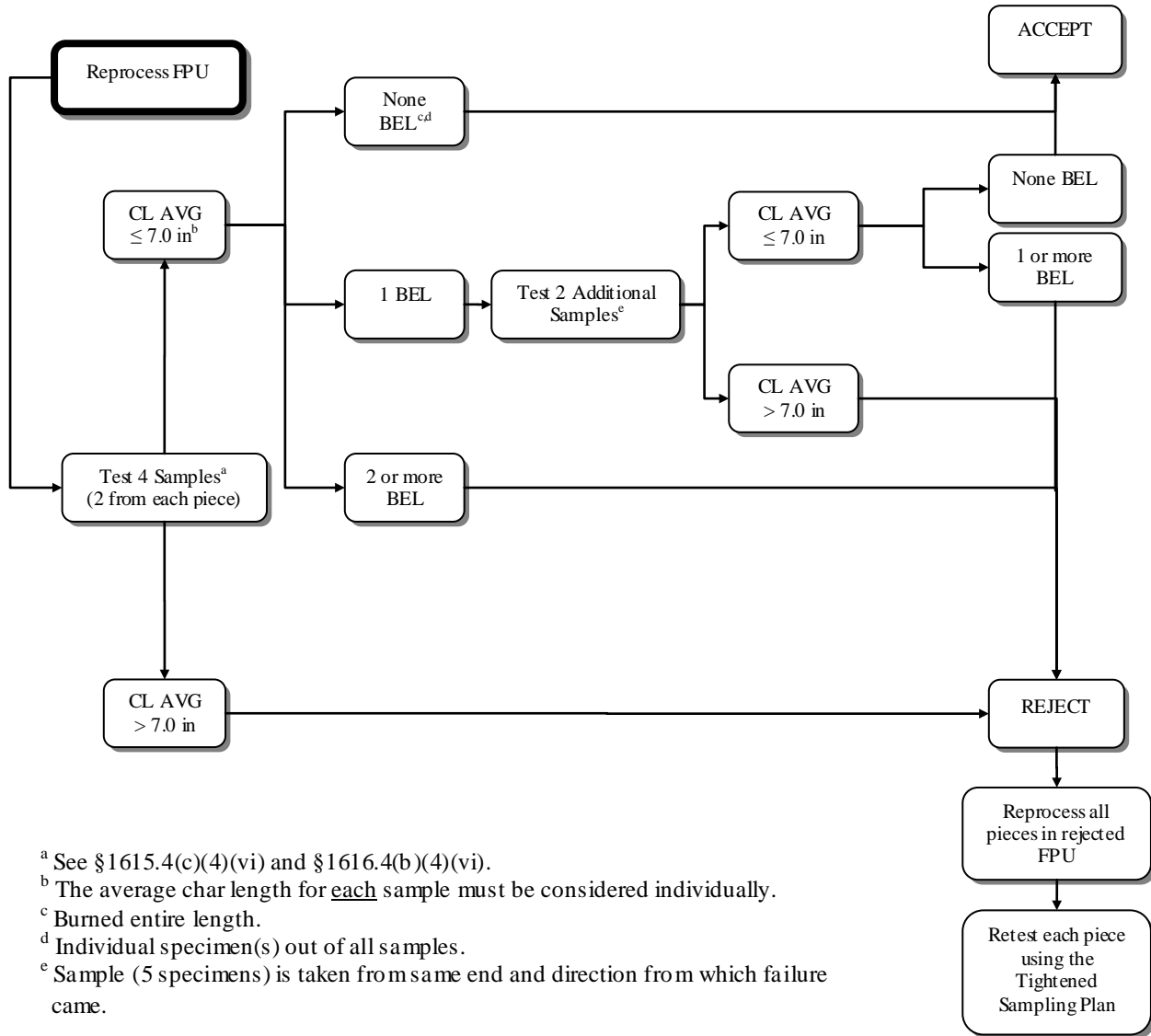

Figure 9. Fabric Production Unit Flowchart (Disposition Testing, Piece by Piece)

8.2 Garment Production Unit Sampling

A garment production unit (GPU) is defined as a quantity of finished garments up to 500 dozen that maintain a specific identity throughout the unit excluding differences in size, trim, findings, color, and print patterns.



Garments with a specific identity are garments made with identical: (1) fabric, (2) thread, and (3) seam construction in the longest seam.

Different solid colors or different print patterns on the same fabric may be included in the same GPU as long as three or more samples from each solid color or print pattern are tested and do not show significantly different results.

Do not combine solid colors and print patterns in the same GPU.

Test multi-layer fabrics with the same edge finish as that used for the garment.

The Garment Sampling Plan is made up of two parts:

- **Prototype Testing**
Prototype testing is used to identify design components or features that impact the flammability performance of a garment before production begins.
- **Production Testing**
Production testing is used to verify the flammability performance found during prototype testing of a garment after full-scale production of that garment.

8.2.1 Prototype Testing

Test seam and trim prototypes pre-production to determine whether or not these constructions could cause an acceptable sleepwear fabric to not meet the acceptance criteria.

Test prototypes of all different seam and trim types used in each garment style included in the GPU according to the procedures outlined in sections 8.2.1.1 *Seams* and 8.2.1.2 *Trim*. See §1615.4(d)(2) and §1616.4(c)(2) for more information.

8.2.1.1 Seams

Test each different seam type to be included in the garments in the GPU. Prepare three 25.4 cm (10 in) long samples (15 specimens) of each seam type. Some example seam types include, but are not limited to, side seams, armholes, collars, and yokes and may be straight, ruffled, gathered, or a combination.



Every seam type in a garment is to be tested. Do not include seams used to attach functional materials or findings (zippers, elastic bands, vinyl foot material, skin tight arm and leg rib bands, skin tight rib collars less than 2.5 cm (1.0 in) wide, and labels). Do not include untrimmed coverbind edge finishes or untrimmed hems (considered decorative trim).

At the same time as prototype test sample preparation, prepare three additional samples (15 specimens) of each seam type for recordkeeping requirements. This ensures that the physical records are identical to the prototype test sample. Note the longest seam to be used in the garment. It will be tested at the production stage.

See section 9. *Sample Preparation* for more information on specimen preparation.

The flowchart in Figure 10 outlines the test sequence and criteria. See §1615.4(d)(2)(i) and §1616.4(c)(2)(i) for more information on the test sequence and criteria.

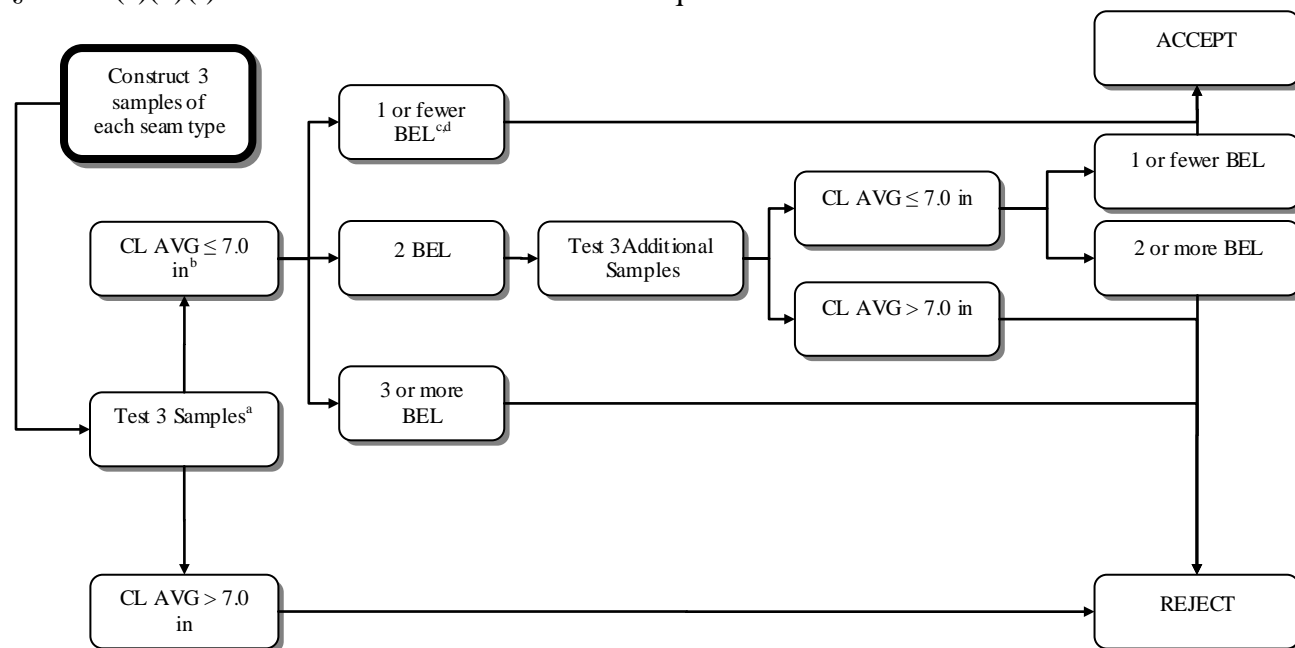

^a See §1615.4(d)(2)(i) and §1616.4(c)(2)(i).

^b The average char length for each sample must be considered individually.

^c Burned entire length.

^d Individual specimen(s) out of all samples.

Figure 10. Garment Production Unit Flowchart (Prototype, Seams)

8.2.1.2 Trim

Test each trim type to be included in the garments. Prepare three samples (15 specimens) for each different type of trim to be used on the garments in a GPU. Attach the trim to a 25.4 cm (10 in) fabric specimen in the same manner that it would be attached to a production garment, using the same thread (or other fastening material), stitch, and seam type.

- For trim used in *horizontal* configurations only (including across the chest or at the bottom edge of the garment), prepare test specimens by attaching the trim horizontally across the bottom edge of the fabric specimen.
- For trim used in *non-horizontal* configurations on a garment (including sleeves and necklines), prepare test specimens by attaching trim to the fabric specimen vertically in the center of the long dimension.



Different colors of trim are considered different trim types.

A trim type tested and accepted in the vertical configuration may be used in a horizontal configuration on the garment without further testing.

See *Appendix F: Trim* for more information on trim.

At the same time as prototype test sample preparation, prepare three additional samples (15 specimens) of each trim type for recordkeeping requirements, thereby ensuring that the physical records are identical to the prototype test sample.

See section 9. *Sample Preparation* for more information on specimen preparation.

The flowchart in Figure 11 outlines the test sequence and criteria. See §1615.4(d)(2)(ii) and §1616.4(c)(2)(ii) for more information on the test sequence and criteria.

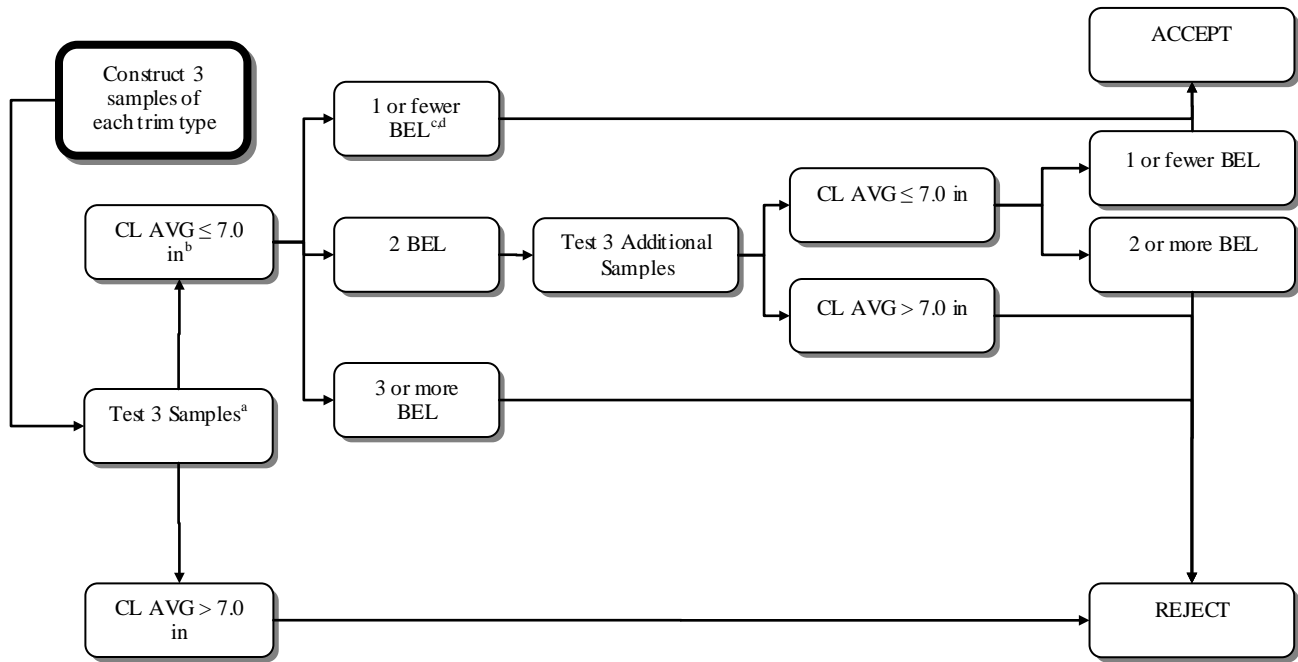

^a See § 1615.4(d)(2)(ii) and § 1616.4(c)(2)(ii).

^b The average char length for each sample must be considered individually.

^c Burned entire length.

^d Individual specimen(s) out of all samples.

Figure 11. Garment Production Unit Flowchart (Prototype, Trim)

8.2.2 Production Testing

Select completed garments from each GPU using a random selection procedure.



If the FPU used to construct the garments has been tested and found acceptable after undergoing the laundering requirements, test the GPU in the finished state (as produced or after one laundering) only.

If the records for the FPU used to construct the garments do not show that it has been tested and found acceptable after undergoing the laundering requirements, test the GPU in the finished state (as produced or after one laundering) and after 50 laundering cycles.

8.2.2.1 Normal Sampling Plan

Test only the longest seam type in the garment. Randomly select a sufficient number of garments from a GPU to obtain three samples (15 specimens) of the longest seam type in the garments.



No more than five specimens may be cut from a single garment.

All specimens from a single garment must be included in the same sample.

When the **longest seam type in the largest size garment produced is less than 10.0 inches long**, accept or reject the GPU as stated in §1615.4(d)(3)(i)(B) and §1616.4(c)(3)(i)(B). If the GPU is rejected, construct three samples containing 10.0 inch long specimens for testing. Use fabric and thread from production inventory to make the 15 specimens. The GPU will then be accepted or rejected using the criteria in §1615.4(d)(3)(i)(A) and §1616.4(c)(3)(i)(A).

See section 9. *Sample Preparation* for more information on specimen preparation.

The flowcharts in Figures 12 and 13 outline the test sequence and criteria. See §1615.4(d)(3)(i) and §1616.4(c)(3)(i) for more information on the test sequence and criteria.

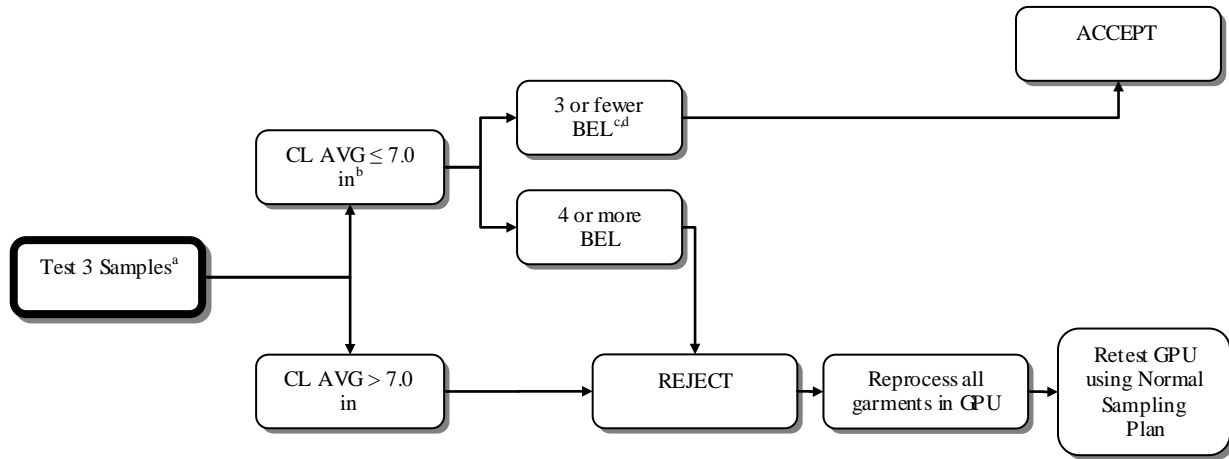

^a See § 1615.4(d)(3)(i)(A) and § 1616.4(c)(3)(i)(A). No more than 5 specimens may be cut from a single garment.

^b The average char length for each sample must be considered individually.

^c Burned entire length.

^d Individual specimen(s) out of all samples.

Figure 12. Garment Production Unit Flowchart (Production, Normal Sampling Plan)

If the longest seam in the garments is less than 25.4 cm (10.0 in) but at least 17.8 cm (7.0 in), follow the flowchart in Figure 13.

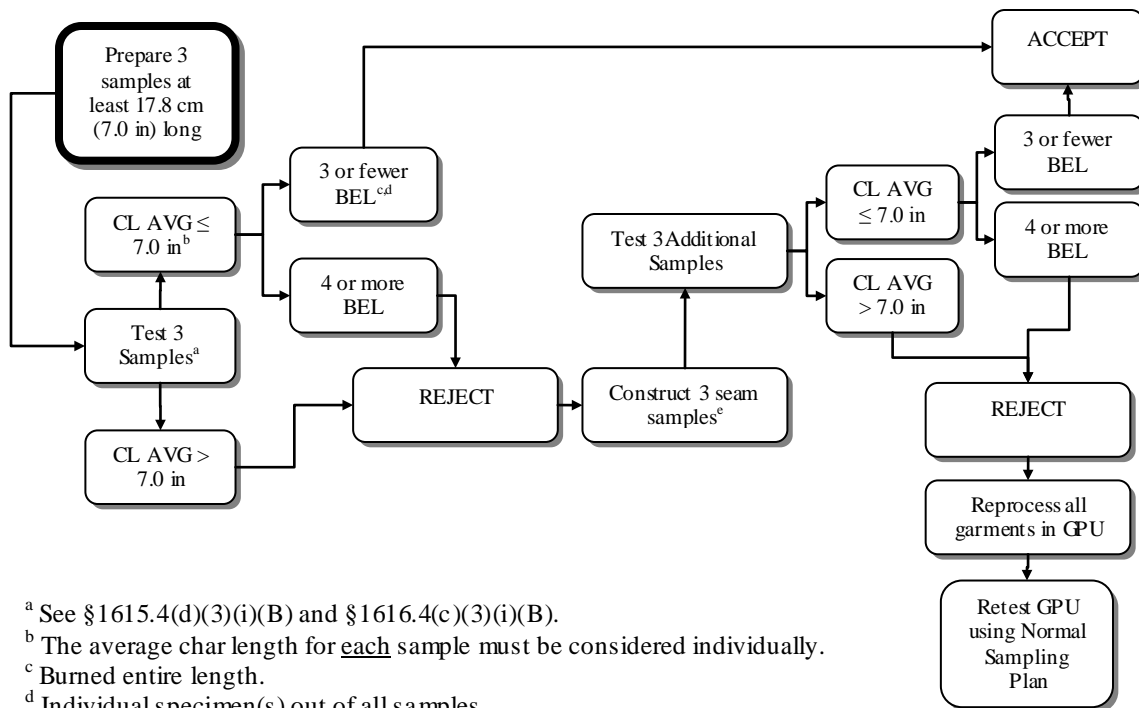

^a See § 1615.4(d)(3)(i)(B) and § 1616.4(c)(3)(i)(B).

^b The average char length for each sample must be considered individually.

^c Burned entire length.

^d Individual specimen(s) out of all samples.

^e Construct seam samples of the longest seam type using production fabric, thread, and operators.

Figure 13. Garment Production Unit Flowchart (Production, Normal Sampling Plan, Modified)

8.2.2.2 Reduced Sampling Plan

For GPUs consisting of **sizes 7 through 14 only**, the Reduced Sampling Plan⁶ may be used after 15 consecutive GPUs have been accepted under the Normal Sampling Plan.

Select garments for testing from two GPUs (500 dozen units each). For selecting, testing, and accepting purposes only, the two GPUs will be considered a single GPU.

Select and test three samples from the GPU. Accept or reject a GPU based on the test criteria shown in Figure 14 of this manual and §1616.4(c)(3)(i,ii). If a GPU is rejected, discontinue use of the Reduced Sampling Plan and resume use of the Normal Sampling Plan.

See section 9. *Sample Preparation* for more information on specimen preparation.

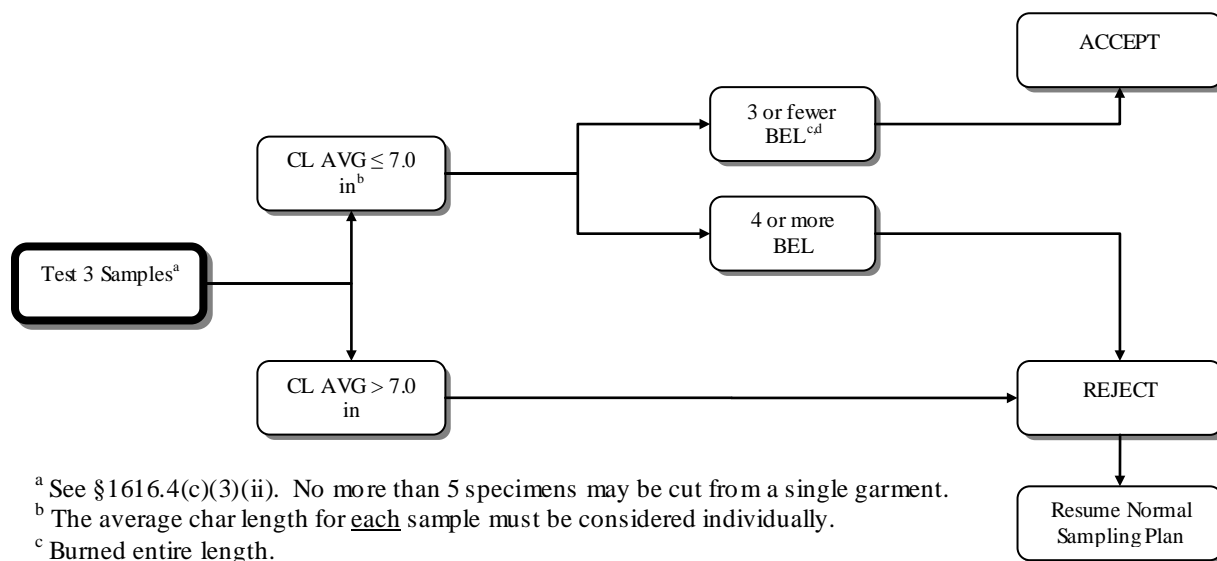

^a See §1616.4(c)(3)(ii). No more than 5 specimens may be cut from a single garment.

^b The average char length for each sample must be considered individually.

^c Burned entire length.

^d Individual specimen(s) out of all samples.

Figure 14. Garment Production Unit Flowchart (Production, Reduced Sampling Plan)

8.2.3 Disposition of Rejected Units

Rejected GPUs cannot be retested, used, or promoted for use in children's sleepwear unless the flammability performance is improved. When the flammability characteristics are improved through further processing, the GPU may be retested following the Normal Sampling Plan. See §1615.4(d)(3) and (4) and §1616.4(c)(3) and (4) for more information on the test sequence and criteria.

⁶ Using the Reduced Sampling Plan is optional, not required.

9. SAMPLE PREPARATION

Equipment List:

- Balance/scale*
- Die/template for preparing fabric weight specimens
- Specimen holders and clips*
- Specimen preparation materials such as scissors, marking pens, and tape
- Specimen template, 8.9 by 25.4 cm (3.5 by 10.0 in)

Procedure:

9.1 Prepare Test Specimens

Using a template or die that will produce swatches of a known area, cut swatches of the test unit fabric in order to determine the fabric weight (g/m^2 or oz/yd^2). Weigh the swatches and average the results to determine the fabric weight⁷.

For each sample, cut five specimens with dimensions 8.9 by 25.4 cm (3.5 by 10.0 in). Prepare two specimens from one direction (warp/machine or filling/cross-machine) and three specimens from the remaining direction. Note the fabric weight on the test report.

In the case of a failure that requires another sample to be tested, cut all five specimens from the same direction as the failing specimen(s).

• **Fabric Specimens**

Refer to section 8.1 *Fabric Production Unit Sampling* and §1615.4(c) and §1616.4(b) to determine the number of fabric specimens to prepare.

Prepare two specimens from one direction (warp/machine or filling/cross-machine) and three specimens from the remaining direction.

For fabric specimens from a garment, prepare two specimens from either the lengthwise or crosswise direction of the garment and three from the other direction.



Figure 15. Use template to prepare fabric specimen.

Multilayer Fabric Specimens

Prepare multilayer fabric specimens with all components over the entire length of the specimens. Sew a 2.5 cm (1.0 in) hem at the bottom of the specimens.

⁷ While not required by the Standards, a useful textile conditioning practice can be found in ASTM D 1776 *Standard Practice for Conditioning and Testing Textiles*. Additionally, a test method for determining fabric weight can be found in ASTM D 3776 *Mass Per Unit Area (Weight) of Fabric*.



Cut multilayer fabric specimens so that the length is 28 cm (11 in).

When preparing multilayer fabric specimens from a garment, cut specimens so that the garment edge finish is at the bottom of the specimen. [§1615.4(b)(8); §1616.4(a)(8)]



In the case of a failure that requires another sample to be evaluated, cut all five fabric specimens from the same direction as the failing specimen(s).

- **Seam Specimens**

To determine the number of specimens to prepare, refer to section 8.2. *Garment Production Unit Sampling*.

- 8.2.1 *Prototype Testing* along with §1615.4(d)(2)(i) and §1616.4(c)(2)(i);
- 8.2.2 *Production Testing* along with §1615.4(d)(3) and §1616.4(c)(3).



Figure 16. Prepare seam specimen.



Prepare seam specimens so that the seam is in the center of the specimen, parallel to the long dimension. For GPU testing, do not cut specimens with intersecting seams.

For Production Testing: If the longest seam type in the garment is less than 10 inches long in the largest size produced, prepare specimens following the procedures in §1615.4(d)(3)(i)(B) and §1616.4(c)(3)(i)(B).

- **Trim Specimens**

To determine the number of specimens to prepare, refer to section 8.2.1 *Prototype Testing* along with §1615.4(d)(2)(ii) and §1616.4(c)(2)(ii).

Prepare fabric specimens on which trim components may be attached. Attach the trim to a fabric specimen in the same manner that it would be attached to a production garment, using the same thread (or other fastening material), stitch, and seam type.

- For trim used in *horizontal* configurations only (including across the chest or at the bottom edge of the garment), attach the trim horizontally across the entire width of the bottom edge of the fabric specimen.
- For trim used in *non-horizontal* configurations on a garment (including sleeves and necklines), attach the trim vertically in the center of the entire length of the long direction of the fabric specimen.
- If multiple rows of a trim type are used in the garment, prepare specimens with the same number of rows and spacing (up to the limit of the specimen size).



For trim incorporated into a seam, prepare specimens using the same trim-seam configuration. Construct the trimmed seam in such a way that the specimen contains the seam-trim configuration in the center of the entire length of the specimen.

For bows or other discrete trim items on a garment, position the trim at the bottom center of the specimen. The bottom edge of the trim piece should be centered and even with the bottom edge of the fabric specimen. (Fig.17)



Figure 17. Attach trim to fabric specimen.

9.2 Mounting the Specimens

Align the lower edge of the specimen with the lower edges of the bottom plate of the specimen holder. (Fig. 18)

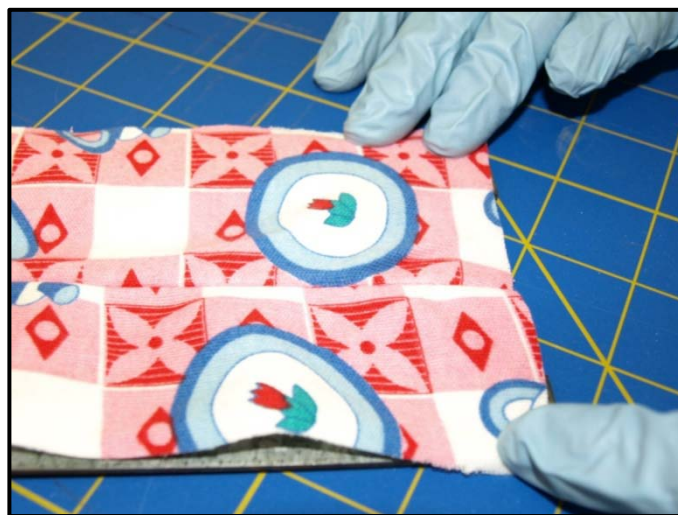

Figure 18. Align specimen with edge of specimen holder.

Smooth the specimen so that it is as flat as possible and slightly taut. (Fig. 19)



Figure 19. Position specimen on back plate.

For seam specimens, position the specimen so that the seam is in the center of the holder opening. (Fig. 20)



Figure 20. Position seam specimen on back plate.

Tape may be used to secure the specimen in the holder. (*Fig.21*)



Figure 21. Tape may be used to further secure specimen.

Use clips to secure the specimen holder plates and test specimen. (*Fig. 22*)



Figure 22. Clips on holders.

10. SAMPLE CONDITIONING

Equipment List:

- Circulating ovens*
- Desiccant*
- Desiccator*
- Gloves, insulated
- High vacuum grease
- Stopwatch*

Procedure:

Pre-heat the circulating oven until it reaches the temperature requirement in §1615.4(a)(9) and §1616.5(a)(9) shown in Table 1.

Table 1. Conditioning Requirements

Oven Temperature	Duration
$105 \pm 2.8 \text{ }^\circ\text{C}$ ($221 \pm 5 \text{ }^\circ\text{F}$)	30 ± 2 minutes



Before starting the conditioning process, check the state of the desiccant in the desiccators. If necessary, refresh the desiccant following the manufacturer's instructions. Check the seal between the desiccator and lid. If necessary, apply high vacuum grease.

Place the mounted specimens in the oven in such a way as to allow air flow around the specimens. Do not allow specimens to touch. (*Fig. 23*)



Figure 23. Place specimens in oven.

Close the oven door and allow the temperature to return to 105 ± 3 °C (221 ± 5 °F). Once the temperature has stabilized, start the timer for 30 minutes. (*Fig. 24*)



Figure 24. Set timer.

After 30 minutes, remove the mounted specimens from the oven using insulated gloves. (*Fig. 25*)



Figure 25. Remove specimens from oven.

Place the mounted specimens in a desiccator to cool. (*Fig. 26*)

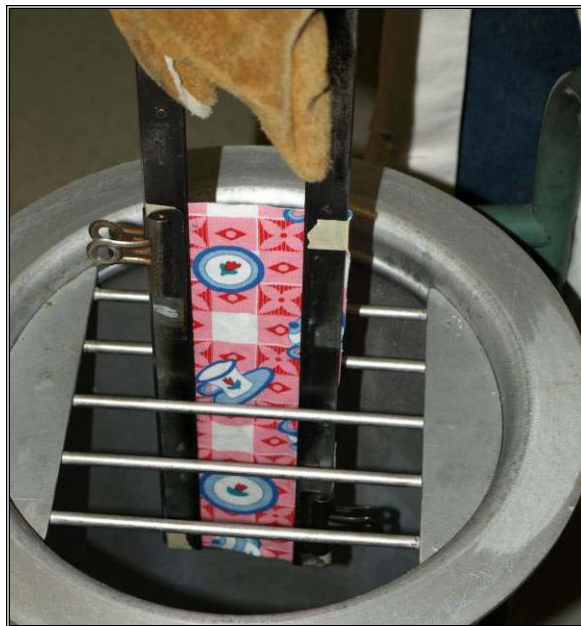

Figure 26. Place specimen in desiccator.

11. TEST PROCEDURE

Equipment List:

- Hooks and weights*
- Liner (non-flammable) for test chamber floor
- Methane, at least 97% pure*
- Regulator*
- Scale (ruler) marked in 1 mm or 0.1 in increments*
- Stopwatch*
- Test chamber (which includes the burner ignition mechanism)*

Procedure:

11.1 Flammability Test

Turn on gas supply to the test chamber and allow air to be displaced from the supply line. Once gas is supplied to the igniter, light the igniter. (*Fig. 27*)

Set the regulator to deliver 129 ± 13 mm Hg (2.5 ± 0.25 psi) of methane to the burner inlet.

With the fume hood turned off, allow the flow to stabilize (approximately 5 minutes). Adjust the flame height to 3.8 cm (1.5 in) by aligning the tip of the flame with the upper prong on the flame height gauge. (*Fig. 28*)

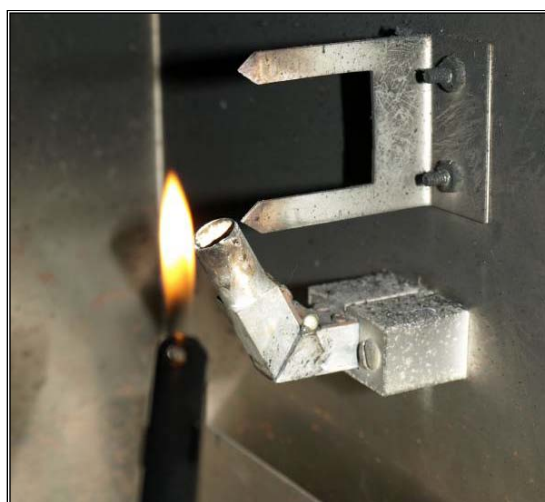

Figure 27. Light igniter.



Figure 28. Check flame length.

Use the fuel valve (highlighted by arrow at right) mounted on the outer right side of the test chamber to adjust the flame length. (Fig. 29) Periodically check (and adjust, if necessary) the test flame length during testing.

The fume hood should be turned off before testing begins.



Figure 29. Use fuel valve to adjust flame length.

Remove a mounted specimen from the desiccator. (Fig. 30)



Replace the desiccator lid between tests.

Begin the test within 30 s of removing the mounted specimen from the desiccator.



Figure 30. Remove specimen from desiccator.

Hang the mounted specimen from the support bar in the top of the test chamber. (Fig. 31)

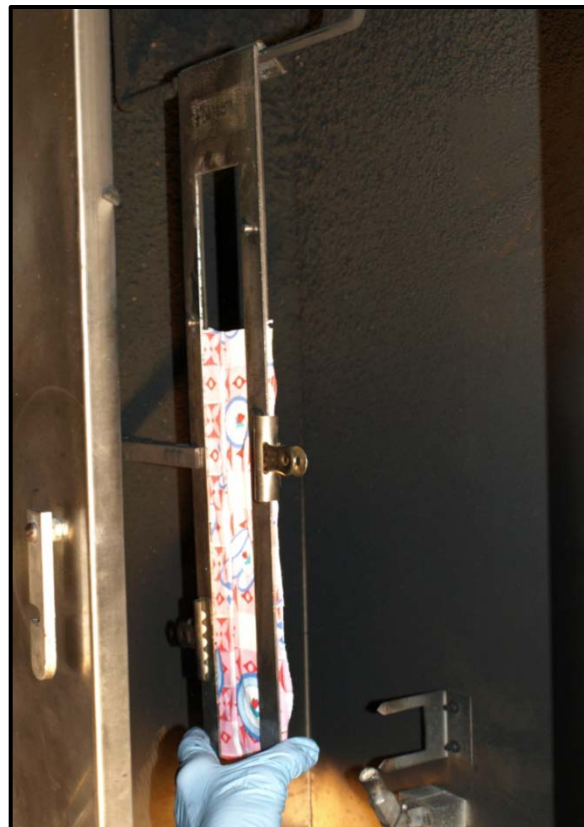

Figure 31. Place specimen on rack.

Adjust the specimen holder so that it slides into the specimen holder guide (highlighted by solid arrow in figure at right) in the back of the test chamber. When the specimen holder is properly positioned, the flame will impinge on the bottom center edge of the specimen (highlighted by dashed arrow in figure at right). (Fig. 32)



Figure 32. Position mounted specimen.

Close the test chamber door and zero the stopwatch. (*Fig. 33*)

Verify that the fume hood is off.



Figure 33. Set stopwatch.

Apply the flame to the specimen by sliding the ignition mechanism forward (see solid arrow in figure at right). Start the stopwatch at the moment the flame impinges on the specimen. (*Fig. 34*)

Once 3 s have passed, remove the flame from the specimen by sliding the burner mechanism back.

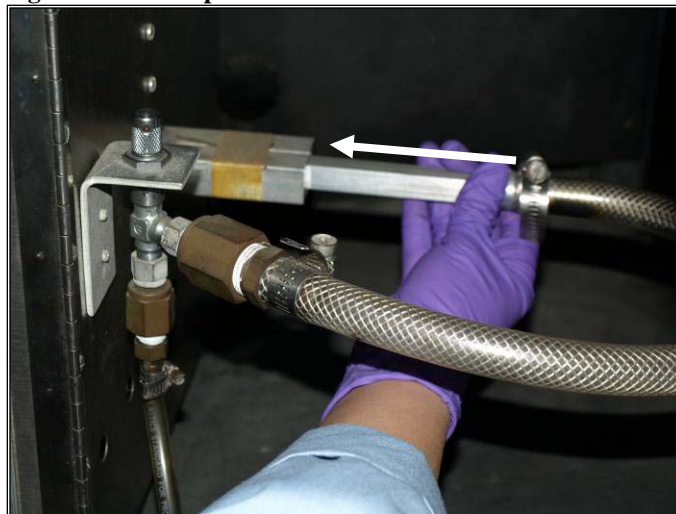

Figure 34. Slide ignition mechanism forward.

Remove the mounted specimen from the test chamber based on the following criteria:

- 16 CFR Part 1615: Once all flaming and/or afterglow⁸ has ceased. [§1615.4(g)(2)(ii)]
- 16 CFR Part 1616: Once all flaming has ceased **except for specimens exhibiting afterglow.** [§1616.5(c)(2)(ii)] The specimens remain suspended in the test chamber for one minute after:
 - All flaming has stopped, or
 - The burner flame impinged on the specimen (if no flaming occurred).

If afterglow remains on a 16 CFR Part 1616 specimen, use the extinguishing plate to suppress any residual afterglow. (*Fig. 35*)

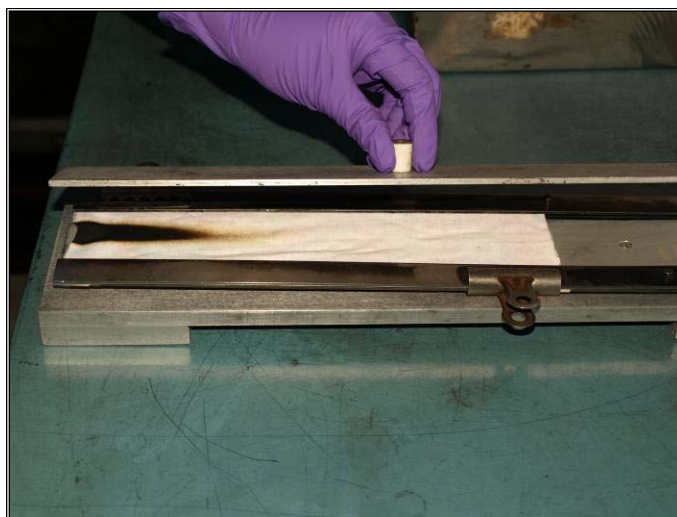

Figure 35. Use extinguishing plate if afterglow is present.

At the end of each test, turn on the fan to exhaust any smoke and fumes produced.

11.2 Char Length Determination

Remove the specimen from the holder and place it on a clean, flat surface. Fold the specimen lengthwise along the highest peak of the charred or melted area. Crease the specimen firmly by hand and unfold. (*Fig. 36*)



Figure 36. Fold specimen.

⁸ 16 CFR Part 1615 has no provision for extinguishing afterglow.

Using the fabric weight determined during sample preparation, select the appropriate weight to use for finding the char length of the specimen (see Table 2). [§1615.4(a)(6); §1616.5(a)(6)]

Table 2. Conditioned Fabric Weight (Finished State)

g/m ²	oz/yd ²	(g)	Load	(lbs)
Less than 101	Less than 3	54.4		0.12
101 to 207	3 to less than 6	113.4		0.25
207 to 338	6 to 10	226.8		0.50
Greater than 338	Greater than 10	340.2		0.75

Hook the appropriate size weight onto the specimen on one side of the charred area approximately 6.4 mm (0.25 in) from the lower edge of the specimen. (Fig. 37)



Figure 37. Hook weight onto specimen.

Grasp the opposite side of the specimen and gently raise the specimen and weight off the supporting surface. (Fig. 38)



Figure 38. Gently lift specimen.

Use a ruler to measure the char length (the distance from the edge of the specimen to the edge of the tear). Record the char length (mm or 0.1 in increments). (*Fig. 39*)

For specimens that burned their full length, record the length of the specimen and note that the specimen burned its entire length.

Calculate and record the average char length of each sample.



Figure 39. Measure char length.

12. LAUNDERING

Equipment List:

- Automatic washing machine and dryer*
- Ballast for laundering*
- Balance/scale*
- Laundering detergent*
- Thermometer or thermocouple

Procedure:

Label all items (fabric pieces/garments) in the test unit with the identification information using an indelible marker.

Launder the test unit following the American Association of Textile Chemists and Colorists (AATCC) Test Method 124-1996, *Appearance of Fabrics after Repeated Home Laundering*. The procedure can be described as option (1)(V)(A)(iii) from Table II of that test method. See Table 3 and §1615.4(g)(4) and §1616.5(c)(4).

Table 3. Washing and Drying Conditions

Washing Cycle	(1) Normal/Cotton Sturdy
Wash Temperature	(V) 60 ± 3 °C (140 ± 5 °F)
Rinse Temperature	< 29 °C (85 °F)
Drying Procedure	(A) Tumble, (iii) Permanent Press

The technical requirements for the laundering procedure are shown in Table 4.

Table 4. Technical Requirements for Laundering

Washing Machine Conditions	Water Level	18 ± 1 gal
	Agitator Speed	179 ± 2 spm
	Washing Time	12 min
	Spin Speed	645 ± 15 rpm
	Final Spin Cycle	6 min
	Wash Load	3.1 to 3.6 kg (7 to 8 lb)
Detergent	AATCC 1993 Std Reference Detergent	Powder
	Amount	66.0 ± 0.1 g
Dryer Conditions	Exhaust Temperature	66 ± 5 °C (150 ± 10 °F)
	Cool Down Time	10 min



Check the indelible markings to be sure that they have not been removed. If they are faint, re-label the test unit items with the identification information.

Weigh the test unit to be laundered and add ballast⁹ to make a maximum wash load of 3.6 kg (8.0 lb).

Fill the wash tub. Use a temperature measuring device such as a thermometer or thermocouple to check the water temperature as the wash tub fills. (Fig. 40)



Figure 40. Check water temperature.



If the water temperature is outside of the stated range as the wash tub fills, empty the wash tub using the spin cycle and refill. Do not add the detergent, test unit items, and ballast until the water temperature is in the stated range.

Weigh 66.0 ± 0.1 g of detergent (AATCC 1993 Standard Reference Detergent, powdered). (Fig. 41)



Remember to tare the scale for the weighing container!



Figure 41. Weigh detergent.

⁹ Refer to *Table 1. Wash Load Ballast* in the AATCC Test Method 124-1996 for fabric type options.

Add the detergent to the wash tub as it fills. Allow detergent to dissolve before adding the items in the test unit and ballast. Add the test unit and ballast before the machine agitation begins.

Wash the test unit and ballast according to the conditions and settings in Tables 3 and 4.

Once the washing process is complete, place the test unit items and ballast in the dryer and dry according to the conditions and settings in Tables 3 and 4. This completes one laundering cycle. Repeat for a total of 50 laundering cycles.



Complete a washing and drying cycle within the same day.

After the laundering process is complete, test the laundered unit according to the test procedure.

13. TEST REPORT AND CERTIFICATION

Record results of all tests performed for each FPU and GPU as specified in §1615.31 and §1616.31.

The following list, although not all inclusive, provides the type of information to record:

- Fabric and/or Garment Production Unit identification and/or any other identifying information
- Fabric state (finished, laundered)
- Fabric weight
- Length of each specimen
- Char length of each specimen tested
- Average char length of each sample tested
- Details of the sampling plan(s) used
- Name and signature of person(s) conducting the tests
- Date tests performed

Maintain all physical and written records required to document compliance with the test procedures and sampling plans as specified by the Standards. See section *14. Recordkeeping* of this manual for more information on the recordkeeping requirements of the Standards.

Certification of the test report should be completed by personnel with an understanding of the test, provided that they did not perform the tests to be certified.

14. RECORDKEEPING

14.1 General

All parties involved in introducing a children's sleepwear product covered by the Standards into commerce must meet a number of recordkeeping requirements. In general, the following information must be included in a product's records. The following list is an overview of these requirements. Refer to the Standards for more complete information.

- Sampling plan(s) used. [§1615.31(e)(1)(i) and §1616.31(d)(1)(i)]
- GPU and FPU identifications of all products marketed and handled. [§1615.31(e)(1)(ii) and §1616.31(d)(1)(ii)]
- Test results. [§1615.31(e)(1)(iii) and §1616.31(d)(1)(iii)]
- Disposition of any products that do not meet the requirements of the Standards. [§1615.31(e)(1)(iv) and §1616.31(d)(1)(iv)]
- Fiber content and manufacturing specifications. [§1615.31(e)(1)(v) and §1616.31(d)(1)(v)]
- Test results used to justify inclusion of different colors or patterns of the same fabric in the same FPU or GPU. [§1615.31(e)(1)(vi) and §1616.31(d)(1)(vi)]
- Test results used to justify reduced laundering. [§1615.31(e)(1)(vii) and §1616.31(d)(1)(vii)]
- Detailed information on any flame retardant treatment used. [§1615.31(e)(1)(viii) and §1616.31(d)(1)(viii)]
- Sales information related to each FPU and GPU. [§1615.31(e)(1)(ix) and §1616.31(d)(1)(ix)]

14.2 Fabrics

For each FPU, maintain the following:

- Finished fabric samples (enough to repeat the sampling procedure) and
- Records that relate the retained samples to the FPU.

See sections §1615.31(e)(2) and §1616.31(d)(2) for more information.

14.3 Garments

14.3.1 Prototype Testing

For each GPU, maintain the following:

- Specifications, fiber content, and details of construction on all seams, fabrics, threads, stitches, and trims used,
- Samples of all seams, fabrics, threads, stitches, and trims used (enough to repeat the sampling procedure),
- A complete, untested garment from each GPU, and
- Remains of all tested specimens.

See sections §1615.31(e)(3) and §1616.31(d)(3) for more information.

14.3.2 Production Testing

For each GPU, maintain the following:

- Source and FPU of all fabrics in GPU,
- Identification and reference to all relevant prototype records and tests,
- Any guaranty used to prove FPU met laundering requirements,
- Proof of random selection of garments from production lot, and
- Written data that will allow the Commission to obtain and test garments under any applicable compliance market sampling plan.

See sections §1615.31(e)(4) and §1616.31(d)(4) for more information.

14.4 Retention Requirements

Retain all records for three years, with the exception of prototype testing used to demonstrate compliance with prototype testing requirements which shall be maintained for three additional years.

APPENDICES

Appendix A: Description of Test Equipment47
Appendix B: Tight-fitting Garments.....49
Appendix C: Definition of Children's Sleepwear and Related Terms54
Appendix D: Exemptions/Exceptions56
Appendix E: Trim57
Appendix F: Glossary of Terms.....59

Appendix A: Description of Test Equipment

Automatic washing machine and dryer: The laundering procedures in the Standards require the use of an automatic washing machine and tumble dryer. The specifications for this equipment are found in §1615.4(g)(4) and §1616.5(c)(4) and in section 12. *Laundering*, Tables 2 and 3 of this laboratory manual.

Ballast for laundering: Add test samples and ballast fabric to make up a wash load of at least 4 lbs. but not greater than 8 lbs. Ballast may be either 100% cotton or 50/50 polyester/cotton blend, as specified in Table 1 *Wash Load Ballast: Finished Fabric Specification* in AATCC Test Method 124-1996.

Burner: The burner ignition mechanism (which is part of the test chamber) is specified at §1615.4(a)(3) and §1616.5(a)(3).

Circulating ovens: Circulating ovens are used to condition test specimens. The Standards specify the use of forced circulation drying ovens capable of maintaining 105 ± 3 °C (221 ± 5 °F) for 30 ± 2 minutes. The Standards reference the test method ASTM D 2654 *Test Methods for Moisture in Textiles* to describe circulating ovens; however, this test method has been withdrawn.

Desiccant: The Standards specify the use of anhydrous silica gel desiccant. Check the desiccant before a test series to determine if it needs to be refreshed. Follow the manufacturer's instructions to refresh the desiccant.

Desiccator: An air-tight and moisture-tight chamber that can accommodate the mounted specimens is used for cooling the specimens after oven drying.

Extinguishing plates: The extinguishing plates are used only when testing per 16 CFR Part 1616. They are used to extinguish afterglow and are described at §1616.5(a)(12).

Gas: Methane, at least 97 percent pure, is specified.

Hood: A hood or other suitable enclosure is used to provide a draft-free environment surrounding the test chamber. The enclosure is equipped with a fan or other means for exhausting smoke and/or fumes produced by testing.

Hooks & Weights: The Standards specify metal hooks and weights to provide a series of loads for char length determination. The hooks and weights are described at §1615.4(a)(6) and §1616.5(a)(6), and the required loads are specified in *Table 1 – Original Fabric Weight* of each Standard.



Figure 42. Weights for char length determination

Laundering detergent: AATCC 1993 Standard Reference Detergent (powdered) is specified by the Standards. This detergent can be obtained from the American Association of Textile Chemists and Colorists (AATCC)¹⁰.

Sewing Machine: A sewing machine capable of constructing seams as well as attaching trim (when sewing is required) as described in the garment sampling plans discussed in section 8.2.1 *Garment Production Unit, Prototype testing* of this laboratory manual and in §1615.4(d)(2)(i)&(ii) and §1616.4(c)(2)(i)&(ii).

Specimen holders: The specimen holder secures the specimen for handling and presentation to the ignition source. The specimen holder consists of two U-shaped steel plates, as specified in §1615.4(a)(2) and §1616.5(a)(2). A specimen is mounted between the plates, which are held together with clips on each side of the U.



Figure 43. Specimen holder

Stopwatch: A stopwatch or similar timing device is used to measure time to 0.1 second.

Regulator: A pressure regulator to deliver the methane gas to the burner under a pressure of 129 ± 13 mm Hg ($2\frac{1}{2} \pm \frac{1}{4}$ psi) at the burner inlet is specified.

¹⁰ American Association of Textile Chemists and Colorists (AATCC), PO Box 12215, Research Triangle Park, NC 27709 (www.aatcc.org)

Appendix B: Requirements for Tight-fitting Garments

In 1996, the CPSC published amendments to both Standards. The amendments included revising the definition of “children’s sleepwear” in the Standards for sizes 0 through 6x and sizes 7 through 14 to exclude tight-fitting sleepwear garments from the requirements of the Standards.¹¹ The purpose of the amendments was to allow tight-fitting garments to be used and sold as sleepwear, thus offering consumers a wider selection of sleepwear garments without diminishing the protection provided by the Standards. Garments termed *tight-fitting* must meet a strict set of measurement criteria. The measurements in Table 5 are the **maximum** allowable dimensions for the seven specified locations for each size of tight-fitting garments. [§1615.1(o); §1616.2(m)] Measure a sample made up of a sufficient number of garments that is reasonable for and representative of the size of the lot produced.

Procedure:

Measure the garment in seven locations.

- Chest
- Waist
- Wrist
- Upper arm
- Seat
- Thigh
- Ankle

- 1) Place the garment face up and flatten the garment, smoothing out any wrinkles. Take all measurements from the front of the garment.
- 2) Multiply each measurement by two in order to find the total measurement.



A tight-fitting garment cannot have any item of fabric or trim that extends more than 0.25 inch from the point at which it attaches to the outer surface of the garment. [§1615.1(o)(2); §1616.2(m)(2)]

¹¹ The amendments also included revising the definition of “children’s sleepwear” in 16 CFR Part 1615 to exclude garments sized 9 months and smaller from the requirements of the Standard.

Table 5. Maximum Measurements for Tight-fitting Children's Sleepwear by Size¹²

Size	Dimensions cm(in)							
	Chest	Waist	Seat	Upper Arm	Thigh	Wrist	Ankle	
9-12 mos ¹³	48.3 (19)	48.3 (19)	48.3 (19)	14.3 (5 ⁵ / ₈)	26.7 (10 ¹ / ₂)	10.5 (4 ¹ / ₈)	13.0 (5 ¹ / ₈)	
12-18 mos	49.5 (19 ¹ / ₂)	49.5 (19 ¹ / ₂)	50.8 (20)	14.9 (5 ⁷ / ₈)	28.3 (11 ¹ / ₈)	10.5 (4 ¹ / ₈)	13.0 (5 ¹ / ₈)	
18-24 mos	52.1 (20 ¹ / ₂)	50.8 (20)	53.3 (21)	15.6 (6 ¹ / ₈)	29.5 (11 ⁵ / ₈)	11.0 (4 ¹ / ₄)	13.6 (5 ³ / ₈)	
2	52.1 (20 ¹ / ₂)	50.8 (20)	53.3 (21)	15.6 (6 ¹ / ₈)	29.8 (11 ³ / ₄)	11.4 (4 ¹ / ₂)	14.0 (5 ¹ / ₂)	
3	53.3 (21)	52.1 (20 ¹ / ₂)	56.0 (22)	16.2 (6 ³ / ₈)	31.4 (12 ³ / ₈)	11.7 (4 ⁵ / ₈)	14.9 (5 ⁷ / ₈)	
4	56.0 (22)	53.3 (21)	58.4 (23)	16.8 (6 ⁵ / ₈)	33.0 (13)	12.1 (4 ³ / ₄)	15.9 (6 ¹ / ₄)	
5	58.4 (23)	54.6 (21 ¹ / ₂)	61.0 (24)	17.5 (6 ⁷ / ₈)	34.6 (13 ⁵ / ₈)	12.4 (4 ⁷ / ₈)	16.8 (6 ⁵ / ₈)	
6	61.0 (24)	55.9 (22)	63.5 (25)	18.1 (7 ¹ / ₈)	36.2 (14 ¹ / ₄)	12.7 (5)	17.8 (7)	
6x	62.9 (24 ³ / ₄)	57.2 (22 ¹ / ₂)	65.4 (25 ³ / ₄)	18.7 (7 ³ / ₈)	37.8 (14 ⁷ / ₈)	13.0 (5 ¹ / ₈)	18.7 (7 ³ / ₈)	
Girl	7	63.5 (25)	58.4 (23)	67.3 (26 ¹ / ₂)	18.7 (7 ³ / ₈)	38.7 (15 ¹ / ₄)	13.0 (5 ¹ / ₈)	18.7 (7 ³ / ₈)
	8	66.0 (26)	59.7 (23 ¹ / ₂)	71.1 (28)	19.4 (7 ⁵ / ₈)	41.3 (16 ¹ / ₄)	13.3 (5 ¹ / ₄)	19.1 (7 ¹ / ₂)
	9	68.6 (27)	61.0 (24)	73.7 (29)	20.0 (7 ⁷ / ₈)	42.6 (16 ³ / ₄)	13.7 (5 ³ / ₈)	19.4 (7 ⁵ / ₈)
	10	71.1 (28)	62.2 (24 ¹ / ₂)	76.2 (30)	20.6 (8 ¹ / ₈)	43.8 (17 ¹ / ₄)	14.0 (5 ¹ / ₂)	19.7 (7 ³ / ₄)
	11	73.7 (29)	63.5 (25)	78.7 (31)	21.0 (8 ¹ / ₄)	45.1 (17 ³ / ₄)	14.3 (5 ⁵ / ₈)	20.0 (7 ⁷ / ₈)
	12	76.2 (30)	64.8 (25 ¹ / ₂)	81.3 (32)	21.6 (8 ¹ / ₂)	46.7 (18 ¹ / ₂)	14.6 (5 ³ / ₄)	20.3 (8)
	13	78.7 (31)	66.0 (26)	83.8 (33)	22.2 (8 ³ / ₄)	47.6 (18 ³ / ₄)	14.9 (5 ⁷ / ₈)	20.6 (8 ¹ / ₈)
	14	81.3 (32)	67.3 (26 ¹ / ₂)	86.4 (34)	22.9 (9)	49.5 (19 ¹ / ₂)	15.2 (6)	21.0 (8 ¹ / ₄)
Boy ¹⁴	7	63.5 (25)	58.4 (23)	66.0 (26)	18.7 (7 ³ / ₈)	37.2 (14 ⁵ / ₈)	13.0 (5 ¹ / ₈)	18.7 (7 ³ / ₈)
	8	66.0 (26)	59.7 (23 ¹ / ₂)	67.3 (26 ¹ / ₂)	19.4 (7 ⁵ / ₈)	38.4 (15 ¹ / ₈)	13.3 (5 ¹ / ₄)	19.1 (7 ¹ / ₂)
	9	68.6 (27)	61.0 (24)	69.2 (27 ¹ / ₄)	20.0 (7 ⁷ / ₈)	39.7 (15 ⁵ / ₈)	13.7 (5 ³ / ₈)	19.4 (7 ⁵ / ₈)
	10	71.1 (28)	62.2 (24 ¹ / ₂)	71.1 (28)	20.6 (8 ¹ / ₈)	41.0 (16 ¹ / ₈)	14.0 (5 ¹ / ₂)	19.7 (7 ³ / ₄)
	11	73.7 (29)	63.5 (25)	73.7 (29)	21.0 (8 ¹ / ₄)	42.4 (16 ⁵ / ₈)	14.3 (5 ⁵ / ₈)	20.0 (7 ⁷ / ₈)
	12	76.2 (30)	64.8 (25 ¹ / ₂)	76.2 (30)	21.6 (8 ¹ / ₂)	43.5 (17 ¹ / ₈)	14.6 (5 ³ / ₄)	20.3 (8)
	13	78.7 (31)	66.0 (26)	78.7 (31)	22.2 (8 ³ / ₄)	44.8 (17 ⁵ / ₈)	14.9 (5 ⁷ / ₈)	20.6 (8 ¹ / ₈)
	14	81.3 (32)	67.3 (26 ¹ / ₂)	81.3 (32)	22.9 (9)	46.0 (18 ¹ / ₈)	15.2 (6)	21.0 (8 ¹ / ₄)

¹² Sizes are based on Department of Commerce Voluntary Product Standards PS 54-72 (previously known as CS 153-48, *Body Measurements for the Sizing of Girls' Apparel*) and PS 36-70 (previously known as CS 155-50, *Body Measurements for the Sizing of Boys' Apparel*).

¹³ Sizes over 9 months and less than 12 months. *Mos* indicates months.

¹⁴ Garments not explicitly labeled and promoted for wear by girls must not exceed these maximum dimensions.

Chest

Measure from arm pit to arm pit (*A* to *B*).

Refer to Diagram 1 in the Standards.



Figure 44. Measure chest.

Waist

One-piece garment: Measure at the narrowest location between the arm pits and crotch.

Two-piece garment: Measure at the bottom or sweep of the upper piece and the top of the lower piece (*C* to *D*).



Figure 45. Measure waist.

Wrist

Measure the width of the end of the sleeve for long sleeves. For sleeves that do not extend to the wrist, the sleeve may not exceed the maximum width of the upper arm and must gradually diminish in width as it approaches the wrist.

Upper Arm

Use a straight-edge to form a line from the waist through the arm pit to the shoulder of the garment. From this point on the shoulder, measure down the arm sleeve using the appropriate value from Table 6. From this point, measure across the sleeve, perpendicular to the top edge of the sleeve.



Figure 46. Measure upper arm.

Table 6. Distance from Shoulder to Upper Arm by Size [cm (in)]

9-12 mos	12-18 mos	18-24 mos	2	3	4	5	6	6x
5.8 (2 ¹ / ₈)	6.6 (2 ⁵ / ₈)	7.4 (2 ⁷ / ₈)	7.4 (2 ⁷ / ₈)	8.1 (3 ¹ / ₄)	8.8 (3 ¹ / ₂)	9.5 (3 ³ / ₄)	10.3 (4)	11 (4 ³ / ₈)

7	8	9	10	11	12	13	14
11.4 (4 ¹ / ₂)	11.7 (4 ⁵ / ₈)	11.9 (4 ³ / ₄)	12.5 (4 ¹ / ₈)	12.8 (5)	13.1 (5 ¹ / ₈)	13.7 (5 ³ / ₈)	14.2 (5 ⁵ / ₈)

Seat

Fold the front of the pant in half to find the bottom of the crotch. Mark the point above the crotch 4 inches perpendicular to the bottom of the crotch (*J* to *K*). Measure through this point across the front panel of the pant (*L* to *M*).



Figure 47. Measure seat.

Thigh

Measure 2.54 cm (1 in) down the inseam from the bottom of the crotch (*J* to *N*). Measure from this point across the pant leg (*N* to *O*).

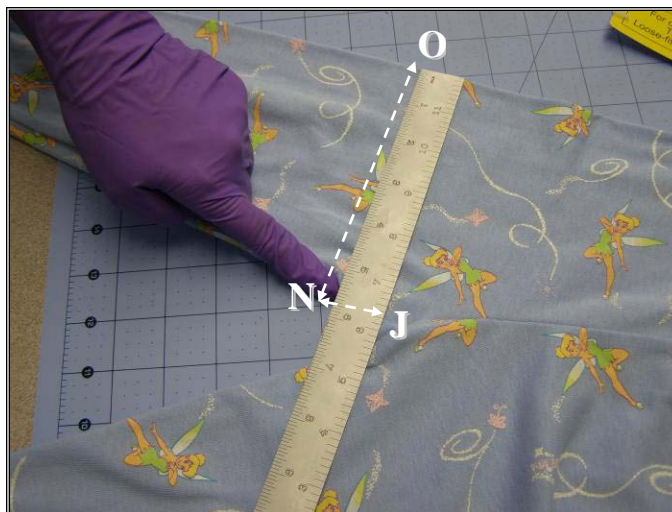

Figure 48. Measure thigh.

Ankle

For pants that extend to the ankle, measure across the width of the end of the pant leg (*P* to *Q*). For shorts or pants that do not extend to the ankle, the pant leg may not exceed the maximum width for the thigh and must diminish in width gradually as it approaches the ankle.



Figure 49. Measure ankle.

Appendix C: Definition of Children's Sleepwear and Related Terms

In 1996, CPSC published amendments to the Standards revising the definition of “children's sleepwear”. In both Standards the amended definition excludes tight-fitting sleepwear garments, while the amended definition in the standard for sizes 0 through 6x also excludes infant garments sized 9 months and smaller.

Children's sleepwear is defined in 16 CFR Part 1615 as

. . .any product of wearing apparel up to and including size 6X, such as nightgowns, pajamas, or similar or related items, such as robes, intended to be worn primarily for sleeping or activities related to sleeping. . . (§1615.1(a); infant garments, sizes 9 months or smaller, are excepted in §1615.1(a)(2) and defined in §1615.1(c)),

and in 16 CFR Part 1616 as

. . .any product of wearing apparel size 7 through 14, such as nightgowns, pajamas, or similar or related items, such as robes, intended to be worn primarily for sleeping or activities related to sleeping. . . (§1616.2(a)).

For enforcement purposes, the following principles guide CPSC staff interpretation of the Standards. (§1615.64; §1616.65)

- Whether fabric or related materials is “intended or promoted” for use in children's sleepwear depends on the facts and circumstances in each case. Relevant factors include:
 1. The nature of the fabric and its suitability for use in children's sleepwear.
 2. The extent to which the fabric or a similar fabric has been sold to manufacturers of children's sleepwear for use in the production of children's sleepwear.
 3. The likelihood that the primary use of the fabric is for production of children's sleepwear garments in a substantial number of cases.
- Whether a product of wearing apparel is “intended to be worn primarily for sleeping or activities related to sleeping” depends on the facts and circumstances present in each case. Relevant factors include:
 1. The nature of the garment and its suitability for use by children for sleeping or activities related to sleeping.
 2. The promotion and distribution of the garment.
 3. The likelihood that the garment will be used by children primarily for sleeping or sleep-related activities in a substantial number of cases.

If a product meets one or more of the principles listed above, it may be considered children's sleepwear in spite of being labeled not to be used for children's sleepwear or for a purpose other than sleepwear (i.e., terms such as, but not limited to, *loungewear*).

Manufacturers, importers, and retailers have an obligation to not introduce a fabric or garment into commerce as children's sleepwear that does not comply with the requirements of the Standards. CPSC staff suggests that manufacturers, importers, and retailers:

- Segregate fabrics and garments used for children's sleepwear from products beyond the scope of the Standards that resemble items of sleepwear.
- Use signs to clearly mark products intended for sleepwear to distinguish them from products that are not to be used for sleepwear.
- Market products that do not comply with the Standards in such a way that they are not viewed mistakenly by a consumer as sleepwear.

Appendix D: Exemptions/Exceptions

There are exceptions to the flammability requirements of the Standards which are listed in §1615.1(a)(1)-(3) and §1616.2(a)(1)-(2).

- Diapers and underwear: Includes long underwear as long as it is marketed as underwear, does not include excessive trim or ornamentation, and/or does not include large designs or prints.
- Infant garments: An infant garment is defined by §1615.1(c) as a garment that is:
 - Sized 9 months or smaller,
 - Length does not exceed
 - One piece garment: 64.8 cm (25.75 in)
 - Two-piece garment: 40 cm (15.75 in) for either piece,
 - Compliant with 16 CFR Parts 1610 and 1611, and
 - Labeled with the size of the garment in terms of age in months.
- Tight-fitting garments: A tight-fitting garment is defined by §1615.1(o) and §1616.2(m) as a garment that:
 - Does not exceed the maximum allowable dimensions for seven specified locations for each size garment, and
 - Complies with 16 CFR Parts 1610 and 1611.

See *Appendix B: Requirements for Tight-fitting Garments* and §1615.1(o) and §1616.2(m).

Appendix E: Trim

Trim is defined in the Standards as “decorative materials, such as ribbons, laces, embroidery, or ornaments.” [1615.1(e), 1616.2(d)]

Trim is tested as part of a Garment Production Unit at the Prototype stage. See sections 8.2.1.2 *Trim* for more information on how to sample and test trim according to the Standards. The orientation of the trim on the base test specimen is determined by the trim location and orientation on the garment. For all test specimens, use the attachment method that will be used in the final garment.

Edge Bindings

Functional edge bindings are considered exempt from the Standards, regardless of color. Bindings that are wider than required by their functional purpose could be considered trim or part of the base garment, depending on the product.

- Piping: Piping with or without a cord is usually determined to be trim and so would be tested during the prototype stage. Piping with a cord that fulfills a functional purpose does not need to be tested.
- Overedge bindings: Merrow (sometimes called *whip* or *crochet stitch*), picot, featherstitching and other overedge stitches used as bindings are considered trim and should be tested in the prototype stage. Attach a length of test unit fabric with the trim binding to the base fabric specimen.

- Ruffles: Test ruffles as trim. Attach a length of the ruffle as it will be used on the garment to the base fabric specimen.



Figure 50. Test ruffles as trim

- Lace: Test lace edging as trim. Attach a length of the lace to the base fabric specimen.
- Elastic edging: Narrow functional elastic that extends no more than 6 mm (0.25 in) from the attachment point on the garment does not need to be tested as trim. Functional elastic includes, but is not limited to, uses such as edge finishing and straps for tank tops. Elastic edging that extends beyond 6 mm (0.25 in) from the attachment point on the garment or is not functional in nature would be tested as trim.



Figure 51. Functional tank strap

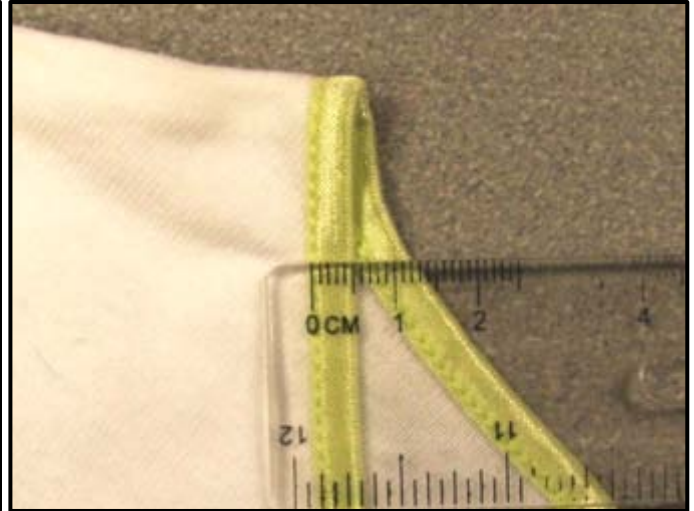

Figure 52. Attachment point less than 6 mm from edge of elasticized trim

Non-edge Binding Items

Test trim pieces that are greater than 5.18 cm (2 in) in the longest direction (including perpendicular to the surface of the garment) or that make up more than 129 cm² (20 in²) on the garment surface.

Orient trim according to its location and orientation on the garment (see section 9.1 *Prepare Test Specimens* for more information).

For decorative stitching such as smocking or embroidery, smock or embroider the design as it will be produced on the garment on the base test fabric and prepare the specimen so that the decorative stitching is at the center of the bottom edge of the specimen.



Figure 53. Test trim pieces greater than 5.18 cm in longest direction

Exclusions

The definition of trim excludes two categories.

- Individual pieces that are less than 2 inches in the longest dimension provided these pieces do not cover more than 20 in² of the garment.
- Functional materials (findings) such as zippers, buttons, or elastic bands used in the construction of the garment. Other examples of functional materials include labels, collars (skin tight and not exceeding 1 inch in diameter), cuffs (for both arms and legs, skin tight), and vinyl-type materials used on the bottom of the feet of sleepwear to prevent slipping and falling.¹⁵

¹⁵ Federal Trade Commission News, March 29, 1972, 1-0329

Appendix F: Glossary of Terms

Afterglow: The continuation of glowing of parts of a specimen after removal of the test flame and after cessation of flaming of the specimen.

Char length: The distance from the original lower edge of the specimen exposed to the flame to the end of the tear or void in the charred, burned, or damaged area.

Children's sleepwear: Any product of wearing apparel sized between nine months and child's 14 intended to be worn primarily for sleeping or activities related to sleeping. Includes items such as nightgowns, pajamas, or similar or related items, such as robes. Diapers and underwear, infant garments, and tight-fitting garments are not included. See *Appendix C* for more information.

Fabric piece: A continuous, unseamed length of fabric, one or more of which make up a production unit.

Fabric production unit (FPU): Any quantity of finished fabric up to 5,000 linear yards for normal sampling or 10,000 linear yards for reduced sampling which has a specific identity that remains unchanged throughout the Unit except for color or print pattern as stated in §1615.4(b) and §1616.4(a).

Finished state: Fabric in its final form (after completing its last processing steps as a fabric except for cutting). Finished state may be "*as produced*" or "*after one washing and drying.*"

Findings: Functional materials such as zippers, buttons, snaps, or elastic bands used in the construction of a garment. Findings are not considered to be trim. See *Appendix E: Trim* for more information.

Garment production unit (GPU): Any quantity of finished garments up to 500 dozen which have a specific identity that remains unchanged throughout the production unit except for size, trim, findings, color, and print patterns as stated in §1615.4(b) and §1616.4(a).

Infant garment: A garment sized nine months and smaller as defined in §1615.1(c). Infant garments are exempt from the sleepwear regulations, but must comply with 16 CFR Parts 1610 and 1611.

Laundering: The process of washing samples with an aqueous detergent solution. Includes rinsing, extraction, and tumble drying. The Standards use a laundering procedure outlined in AATCC Test Method 124-1996.

Multilayer fabric: A fabric that is composed of more than one fabric layer. These fabric layers act as a composite in a finished garment.

Sample: A grouping of five test specimens.

Specimen: An 8.9 x 25.4 cm (3.5 x 10 in) section of fabric. A specimen may include a seam or trim.

Tight-fitting garment: A tight-fitting garment does not exceed the maximum dimensions specified for each size at the chest, waist, seat, upper arm, thigh, wrist, and ankle as stated in §1615.1(o)(1)(i) and

§1616.2(m)(1)(i). Tight-fitting garments are exempt from the flammability testing requirements of the Standards, but must comply with 16 CFR Parts 1610 and 1611.

Trim: Decorative materials, such as ribbons, laces, embroidery, or ornaments. Trim does not include: (1) individual pieces less than 2 inches in their longest dimension, provided that such pieces do not constitute or cover in aggregate a total of more than 20 square inches of the item, or (2) functional materials (findings), such as zippers, buttons, or elastic bands, used in the construction of garments. See *Appendix E: Trim* for more information.